

客服热线  400-861-8111

Leading professional equipment and service provider for energy efficiency automation

Cre~~at~~ a better life with smart drive

Manufacturer:

Shenzhen Micno Electric Co., Ltd.

Address: 4th Floor, Building 1, Invengo RFID Industrial
Park, Tongguan Road, Jiazitang, Guangming District,
Shenzhen, China

Zip code: 518132

Tel: 0755-21675213

Fax: 0755-21675200

Email: acdrive@micno.com.cn

Website: www.micnodrive.com

Information may be subject to change without notice during product improving.

HE1000 Medium Voltage Variable Frequency Drive

Industrial Drive 3kV to 11kV (250 KW to 20,000 KW)

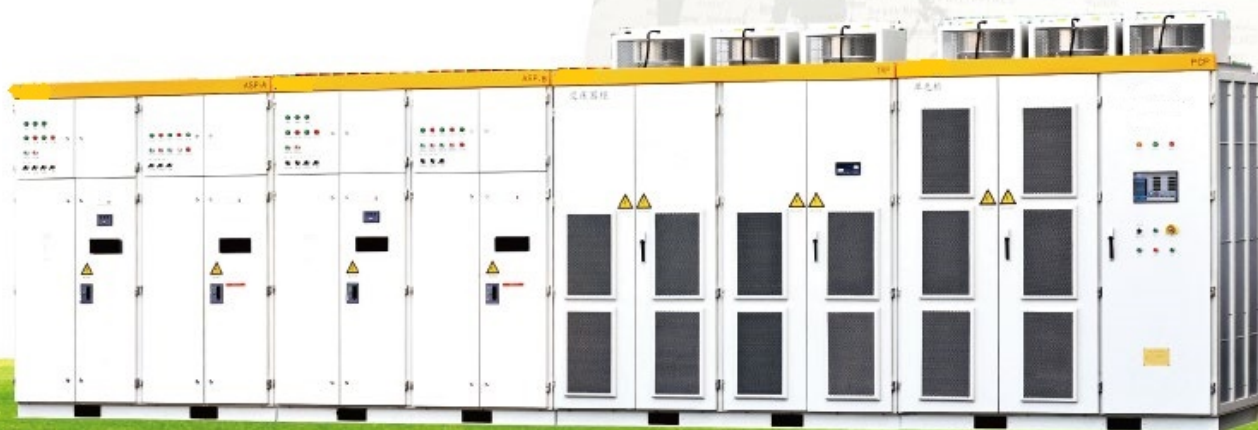

Stock code: 839477



Scan for more

Company Profile



Shenzhen MICNO Electric Co., Ltd. is a national high-tech enterprise, which specializes in R&D, manufacture, sale and service of electrical drive, industrial automation products. MICNO headquarters is located in Guangming District Shenzhen city, has modern office and professional factory. MICNO has been a public company of NEEQ in China in 2016, with stock code 839477.

MICNO masters the leading synchronization, asynchronous current vector control technology, torque control technology and solar pump driving technology, including the main products such as general purpose inverter, various kinds of inverters

of special industries and solar pump inverter. The products cover 220V, 380V, 460V, 525V, 660V, 1140V, 3300V, 6600V, 11000V voltage level with 0.4kW~20MW power range, which are widely used in electric power, metallurgy, petroleum and chemical, mining textile and chemical fiber, printing and packaging, paper-making, machine tool, plastic, hoisting, solar agricultural irrigation and other industries.

With "Market-oriented, Customer-centric" business philosophy, MICNO provides high cost performance products and service to customers, make the customers more competitive. The sales and service network is nationwide in domestic market. And our products have also been exported to more than 60 countries all over the world.

MICNO adheres to the enterprise core value of "Quality, Innovation, Integrity, Win-Win", dedicated to be the world famous supplier of products and services in the electric drive, industrial automation control fields, and would like to achieve customer, staff and enterprise values growing together. Service outlets.



Contents >>>

Product Overview	3
Model and Parameter Table	5
Technical Principle	9
Control Characteristics	15
Power Frequency Bypass	21
General Product Series	23
Dedicated Product Series	25
Standard Wiring Diagram	30
Installation and Use Requirements	31
Storage, Transportation, and Hoisting Requirements	33
Model Selection Instruction	34
Typical Customers	35
Typical Cases	36
Service Cooperation Win-win Result	37



Product Overview

HE1000 MVVFD is a product in the lineup of reliable variable frequency, speed regulation, and energy savings drives, developed, designed and produced by Micno based on years of cooperation with ABB, a worldwide well-known electric company, and on its own rich practical experience in the electric drive and the automation engineering application for almost 20 years, with effective absorption of leading-edge technologies and in consideration of China's actual conditions. Adopting the state-of-the-art technology of flux optimization and control with space vector PWM in China, this product features flux optimization function, high hardware reliability, excellent performance, operating system in Chinese, high overload capacity, superb adaptability to various power grids, and high starting torque. Therefore, it is more applicable to power grid and industrial equipment in China. Voltage classes of HE1000 MVVFD cover 3kV/3.3kV/4.16kV/6 kV/6.6kV/10kV/11kV. Product series include the general MVVFD series, the dedicated MVVFD series for the synchronous motor, the dedicated MVVFD series for the belt conveyor, the four-quadrant MVVFD series, the soft-start and synchronous undisturbed switching MVVFD series. Micno products are widely applied in all types of loads like draught fans, pumps, compressors, internal mixers, belt conveyors, and hoisters and have won high and wide praise from users. Micno is engaged to delivering MVVFDs with the highest quality and best cost performance in China.

Technical Parameters

Medium voltage input	Voltage range	3KV, 3.3KV, 4.16KV, 6KV, 6.6KV, 10KV, 11KV (-20%~+15%)
	Frequency range	50/60Hz ±10%
	Output voltage	0~Rated voltage
Medium voltage output	Output frequency and accuracy	0~50/60 Hz, 0.01 Hz
	Output waveform	Multilevel PWM sin wave, total harmonic distortion (THD) < 4%
Performance	Efficiency	Inversion efficiency at an rated load > 98.5%, overall efficiency (including the transformer) > 97%
	Power factor	Power factor (within the range of speed regulation) > 0.95, power factor (at a rated load) > 0.97
	Overload capacity	110%: long-term stable operation, 120%: 1 minute, 150%: 2 seconds, and 160%: prompt protection
	Allowable outage duration	200 ms (and longer under light load)
	Mean time between failures	> 100,000 hours
Control	Control mode	flux optimization and control with space vector PWM
	Acceleration/deceleration time	1 to 980 seconds
	Switching quantity input/output	9-way/12-way (Be extensible)
	Analog input	2-way (optional: 0 to 10 V, 4 to 20 mA) (Be extensible)
	Analog output	2-way (optional: 0 to 10 V, 4 to 20 mA) (Be extensible)
	Communications	RS485 interface, Modbus-based (optional Profibus-DP and Ethernet interfaces)
Excitation control (dedicated for the synchronous motor)	Control power supply	Single-phase 220 V AC, 5kVA
	Control mode	Automatic excitation control, manual excitation control, multi-stage speed excitation control, and external excitation control for the MVVFD
Environment	Operating environment	Operating in indoor environment without explosive or corrosive gases, conductive dust, or oil fog
	Operating ambient temperature	0~+40°C
	Storage and transportation temperature	-40°C ~+70°C
	Ambient humidity	< 90% (No condensation)
	Operating altitude	Derating required for an altitude greater than 1000 meters
Others	Protection function	Overcurrent, overload, short circuit, three phase current unbalance, immediate electric outage, input/output phase loss, overvoltage, undervoltage, body overheat, transformer overheat, shutdown due to external fault, and power unit auto bypass
	Cooling mode	Forced-air cooling by a cooling fan that comes with MVVFD
	User interface	An 10-inch full Chinese operation interface with true-color touchscreen
	Protection grade: IP31	IP31
	Noise level	< 75 dB(A)

Product Structure

HE1000 MVVFD includes integrated structure and split-type structure based on capacity. The integrated structure is adopted in low capacity.MVVFD The split-type structure is adopted in high capacity MVVFD. In terms of an integrated machine, which is compact in size, a transformer, unit, control, and power frequency bypass are partially integrated into a cabinet and partitioned according to their functions. In terms of a split-type machine, a transformer, unit, control and power frequency bypass are assembled in separate cabinets in which are combined on the spot.

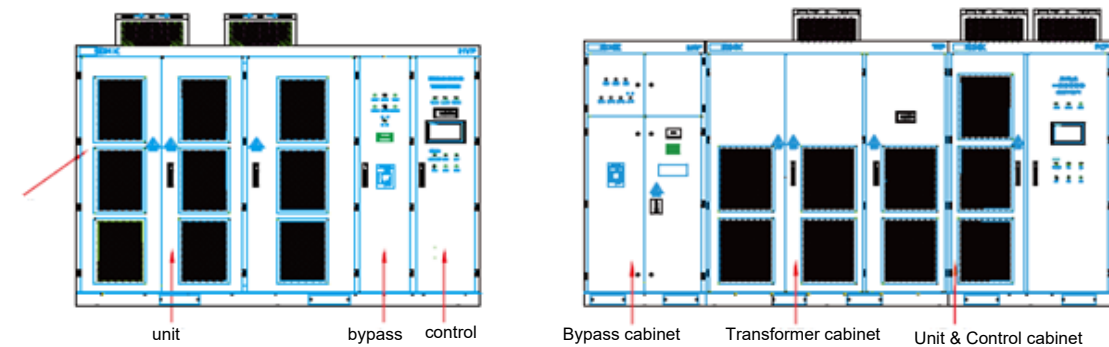

Diagram of a cabinet integrating a transformer, unit, control, and bypass

Diagram of a split-type machine

Code for model designations

HE1000		—	0500		—	0108		—	03	
Symbol	Series Name	Symbol	Rated output power	Symbol	Rated output current	Symbol	Input voltage			
HE	represents the perfect harmony HVVFD	0500	500kW	0108	108A	03	3300V			
1000	represents the energy-saving HVVFD series	0900	900kW			06	6000V			
						10	10000V			

Option description:

Anti-condensation controller kit-----PCCU

Motor differential protection kit-----MDPU

Special options-----TXXX

Uninterrupted power supply— UPS

DC power inverter----DPS

Communications interface modules-----PBDP, ETH, and GPRS

Background monitoring software----MTXX

For example, HE1000-1000-0118-06 represents that this MVVFD, with the output voltage and rated capacity as 6 kV and 1000 kW respectively, rated output current 118A, and it is applied in asynchronous motor.

Model parameter table

HE1000 MVVFD 10 kV output level

Model	Rated Capacity of the MVVFD (kVA)	Rated Power of the Matching Motor (KW)	Rated Currency of the Matching Motor (A)	Overall Dimension (W*D*H) (Including the draught fan height)	Weight (Kg)
HE1000-0250-0018-10	315	250	18	2690×1600×2500	2420
HE1000-0280-0020-10	350	280	20		2440
HE1000-0315-0023-10	400	315	23		2460
HE1000-0355-0026-10	450	355	26		2480
HE1000-0400-0029-10	500	400	29		2500
HE1000-0450-0032-10	560	450	32		2560
HE1000-0500-0035-10	630	500	35		2630
HE1000-0560-0040-10	710	560	40		2700
HE1000-0630-0044-10	800	630	44		2800
HE1000-0710-0050-10	900	710	50		2900-
HE1000-0800-0056-10	1000	800	56		3000
HE1000-0900-0062-10	1120	900	62		3120
HE1000-1000-0072-10	1250	1000	72		3250
HE1000-1120-0077-10	1400	1120	77		3400
HE1000-1250-0086-10	1600	1250	86		3600
HE1000-1400-0096-10	1750	1400	96		4150
HE1000-1600-0110-10	2000	1600	110		4400
HE1000-1800-0125-10	2250	1800	125		4650
HE1000-2000-0137-10	2500	2000	137	4900	
HE1000-2250-0156-10	2800	2250	156	5620	
HE1000-2500-0171-10	3150	2500	171	6000	
HE1000-2800-0192-10	3500	2800	192	6500	
HE1000-3150-0216-10	4000	3150	216	8400	
HE1000-3550-0245-10	4500	3550	245	9000	
HE1000-4000-0275-10	5000	4000	275	9500	
HE1000-4500-0311-10	5600	4500	311	10800	
HE1000-5000-0342-10	6300	5000	342	11800	
HE1000-5600-0383-10	7000	5600	383	12500	
HE1000-6300-0431-10	8000	6300	431	13500	
HE1000-7100-0485-10	9000	7100	485	Please consult us.	
HE1000-8000-0550-10	10000	8000	550		
HE1000-9100-0621-10	11500	9100	621		
HE1000-10000-0685-10	12500	10000	685		
HE1000-12500-0855-10	16000	12500	855		
HE1000-15000-1030-10	19000	15000	1030		
HE1000-18000-1240-10	22500	18000	1240		
HE1000-20000-1380-10	25000	20000	1380		

Bypass cabinet model selection table

Product Name	Product Model	Rated Currency (A)	Size (W*D*H)	Rated voltage (kV)	Weight (Kg)
Manual "one drives one" bypass cabinet	HE1000-MSP0400-A-10	400	890*1400*2025	10	400
	HE1000-MSP0630-A-10	630		10	425
	HE1000-MSP1250-A-10	1250		10	450
Manual "one drives two" bypass cabinet	HE1000-MSP0400-AB-10	400	1740*1400*2025	10	750
	HE1000-MSP0630-AB-10	630		10	800
	HE1000-MSP1250-AB-10	1250		10	850
Automatic "one drives one" bypass cabinet	HE1000-ASP0250-A-10	250	1300*2200*1300	10	500
	HE1000-ASP0400-A-10	400		10	525
	HE1000-ASP0630-A-10	630		10	550
Automatic "one drives two" bypass cabinet	HE1000-ASP0250-AB-10	250	1740*1400*2025	10	950
	HE1000-ASP0400-AB-10	400		10	1000
	HE1000-ASP0630-AB-10	630		10	1050

Note: The equipment dimensions and weight are for reference only. They are subject to change without notice.

Model parameter table

HE1000 MVVFD 6kV output level

Model	Rated Capacity of the MVVFD (kVA)	Rated Power of the Matching Motor (KW)	Rated Current of the Matching Motor (A)	Overall Dimension (W*D*H) (Including the draught fan height)	Weight (Kg)
HE1000-0250-0029-06	315	250	29	2690×1600×2500	2245
HE1000-0280-0032-06	350	280	32		2280
HE1000-0315-0036-06	400	315	36		2330
HE1000-0355-0042-06	450	355	42		2380
HE1000-0400-0046-06	500	400	46		2430
HE1000-0450-0052-06	560	450	52		2490
HE1000-0500-0057-06	630	500	57		2560
HE1000-0560-0066-06	700	560	66		2630
HE1000-0630-0072-06	800	630	72		2690
HE1000-0710-0082-06	900	710	82		2740
HE1000-0800-0092-06	1000	800	92		2840×1725×2500
HE1000-0900-0105-06	1120	900	105	3370	
HE1000-1000-0115-06	1250	1000	115	3500	
HE1000-1120-0129-06	1400	1120	129	3650	
HE1000-1250-0143-06	1600	1250	143	3850	
HE1000-1400-0161-06	1750	1400	161	4150	
HE1000-1600-0183-06	2000	1600	183	4400	
HE1000-1800-0206-06	2250	1800	206	4190×1600×2865	5030
HE1000-2000-0230-06	2500	2000	230		5330
HE1000-2250-0257-06	2800	2250	257		5640
HE1000-2500-0285-06	3150	2500	285		6000
HE1000-2800-0320-06	3500	2800	320	5480×1600×2865	7700
HE1000-3150-0360-06	4000	3150	360		8250
HE1000-3550-0405-06	4500	3550	405	Please consult us.	8750
HE1000-4000-0460-06	5000	4000	460		
HE1000-4500-0512-06	5600	4500	512		
HE1000-5000-0570-06	6300	5000	570		
HE1000-5600-0637-06	7000	5600	637		
HE1000-6300-0720-06	8000	6300	720		
HE1000-7100-0810-06	9000	7100	810		
HE1000-8000-0915-06	10000	8000	915		
HE1000-9100-1050-06	11500	9100	1050		
HE1000-10000-1145-06	12500	10000	1145		

Model selection table description

- The equipment dimensions and weight are for reference only. They are subject to change without notice.
- To ensure that the MVVFD runs steadily and reliably for a long time and to prolong its service life, sufficient headroom should be left during the design of the power of the heat exchanger for cooling the MVVFD room. It is recommended that 4% of the rated power of the MVVFD should be left to the heat exchanger. Multiple factors should be taken into account such as the local temperature, room size and leak tightness during the design of the MVVFD room. Select appropriate ventilation and refrigeration equipment for the MVVFD room. It is recommended that the exhaust air rate should be not less than 1 m³/s per 10 kW loss when the mode of ventilation for heat exchange is adopted and the air conditioner power should be not lower than 4 P per 10 kW loss when an air conditioner is adopted for cooling.
- Please consult us for more information about products with other capacity levels or special voltage levels (for example, 3.3 kV 、 4.16 kV 、 6.6 kV or 11 kV).
- Please consult us for more model information about the dedicated MVVFD for belt conveyor, the dedicated MVVFD for internal mixer, four-quadrant MVVFD series, soft-start synchronous undisturbed switching MVVFD series.
- Please consult us for more information about the products with higher power

Technical principle

HE1000 MVVFD is an energy-saving high voltage variable frequency drive boasting high reliability. It is developed, designed, and produced by Micno based on rich practical experience in electric drive and automation engineering application for many years and in consideration of actual situation of China, by using state-of-the-art technologies of flux optimization and control with space vector sinusoidal wave PWM and adopting industrial-grade digital signal microprocessor, large scale integrated circuit chip, and highly reliable IGBT power component of the new generation. With the mature technology of connecting power units in series and based on the principle of superimposed voltage rise, HE1000 MVVFD directly drives a high-voltage motor with the output high voltage. It has the perfect harmony function and meets the application requirements of various industrial fields. Micno is engaged to providing high voltage variable frequency, and energy-saving drives with the highest reliability.

Main circuit structure

HE1000 MVVFD adopts a structure of multiple units connected in series. Its main circuit is mainly composed of a multi-winding transformer and several inverter units. Power for each inverter unit is supplied via individual multi-winding supply transformer. Power supplies for inverter units are isolated from each other and they are isolated from the power grid. The inverter unit is the core power component with IGBT as its switching component. The typical main circuit of a 6 kV VFD is composed of 15 units and a phase is composed of 5 units connected in series, configured in Y-shaped connection. The typical main circuit of a 10 kV VFD is composed of 24 units and a phase is composed by every 8 units with Y-shape series connection. Select a VFD with the structure of 6 kV/6 units or 10 kV/9 units according to specific requirements.

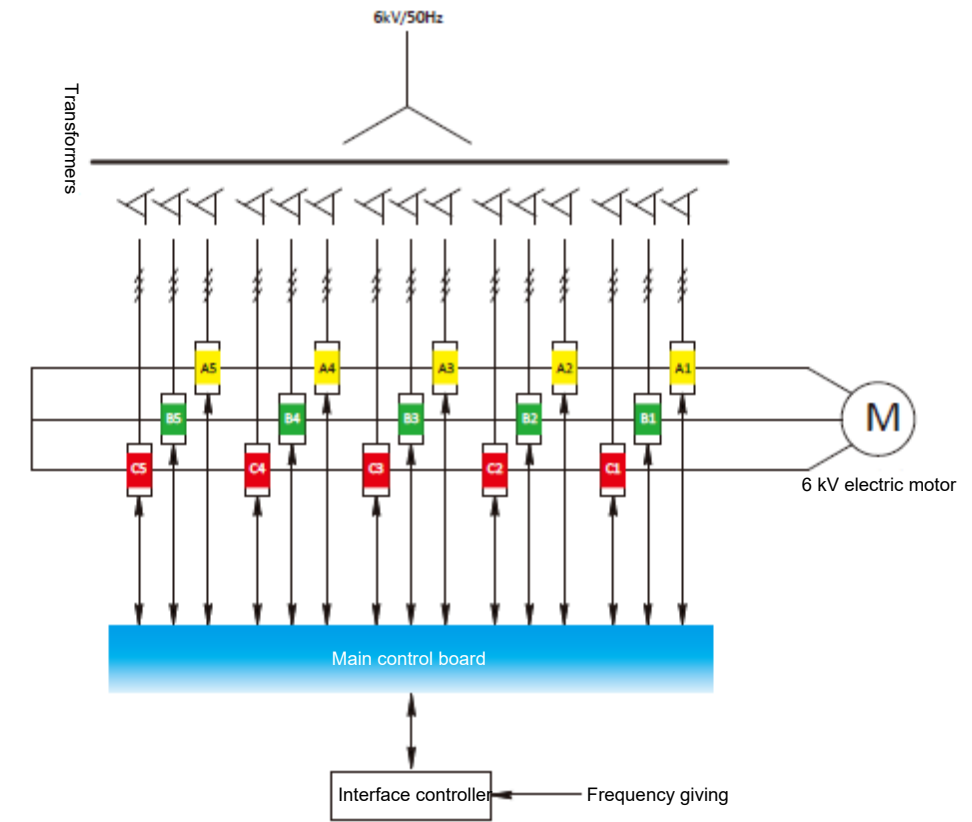
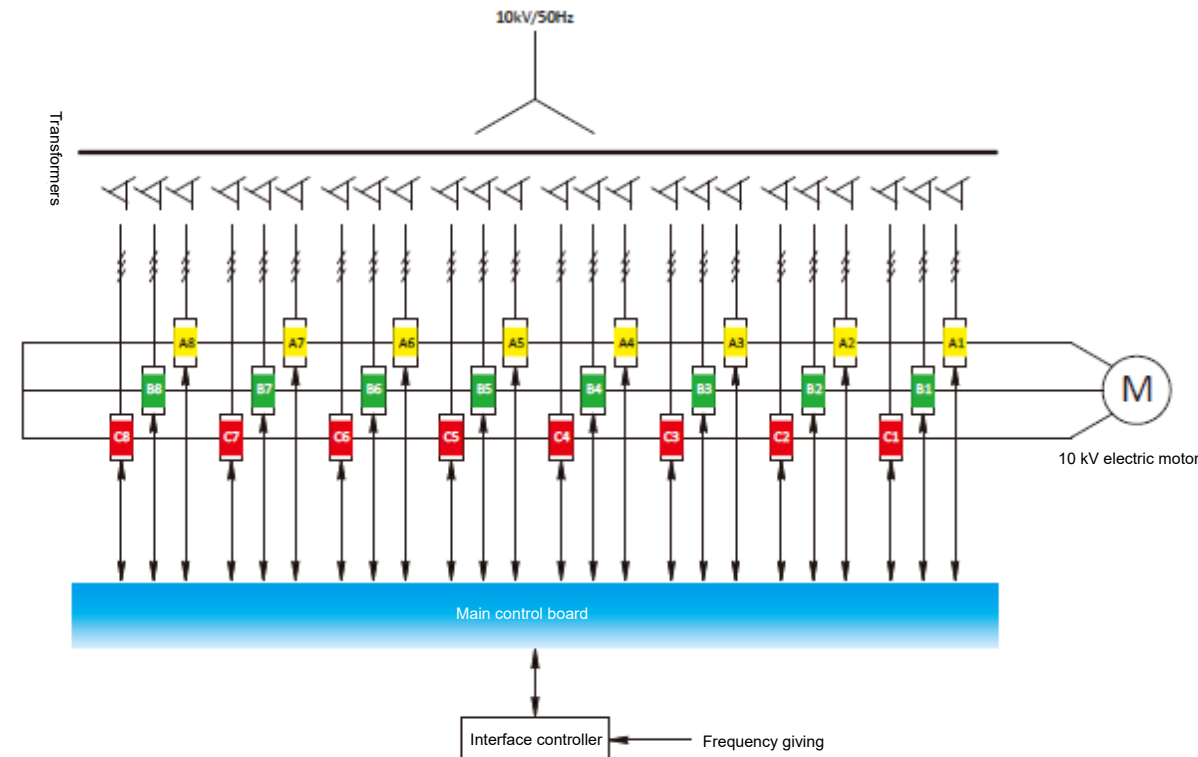

Principle of power over the input side phase-shifting transformer

The input side of HE1000 MVVFD is configured with a multi-winding isolation transformer. The secondary side of the transformer includes multiple isolated three-phase windings. Every 3 three-phase windings form a in-phase group, separately supplying individual power for 3 units, and forming 6-pulse rectification input. 6 kV HE1000 has 5 in-phase groups forming 30-pulse input. 10 kV HE1000 has 8 in-phase groups forming 48-pulse input.

In the same way, 6 kV HE1000 consisting of 6 units connected in series has 6 in-phase groups, which forms 36-pulse input. 10 kV HE1000 consisting of 9 units connected in series has 9 in-phase groups, which forms 54-pulse input.

Good grid-side performance index of HE1000 is benefiting from its characteristic of multi-pulse input. The input waveform is similar to a perfect sine wave, which fully meets the requirements of IEEE519-1992 and GB/T14549-2002 standards and can ensure an input power factor of near 1.0.

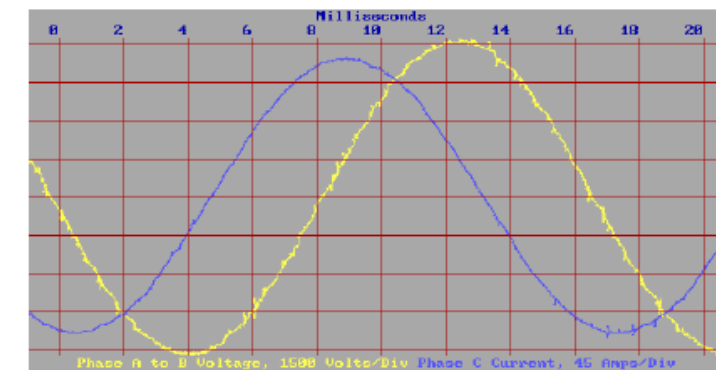

Input voltage and current waveforms

Principle of superposition of inverter of units at the output side

The output voltage of HE1000 is composed of multiple 3-phase input voltages and single-phase output voltage for inverter of low voltage power unit in series. As shown in the figure below, several inverter units are divided into 3 groups. Each group has the same number of units. The phase difference between voltages of different groups is 120 degrees. Three groups of units are configured in Y-connection on the output and a three-phase high voltage power supply with variable voltage and frequency is obtained required by the driving motor.

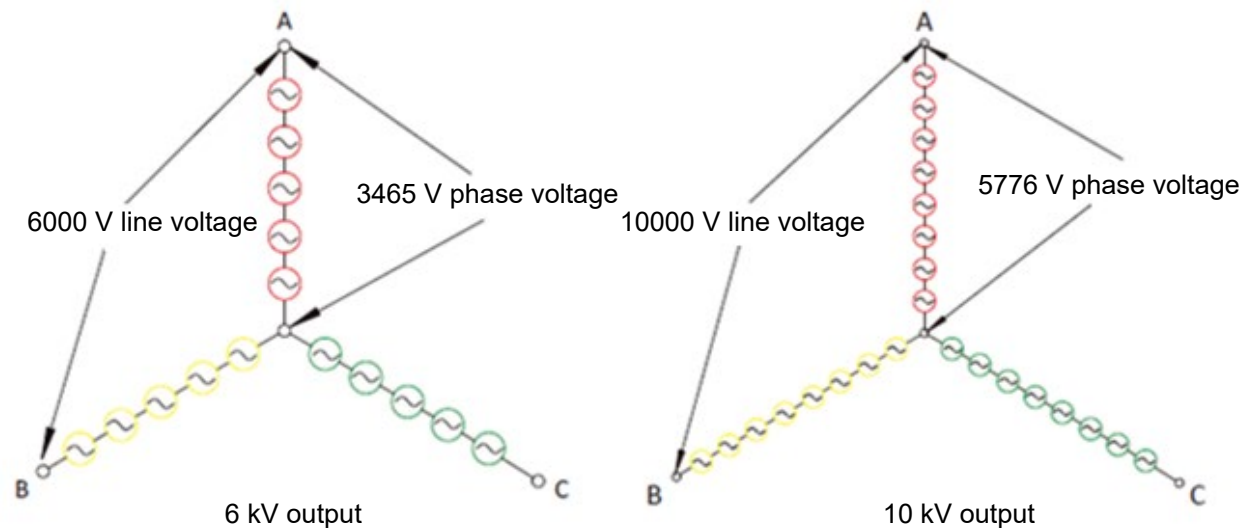

Each inverter unit outputs the PWM sine wave. The multiple technologies are adopted in units connected in series. That is to say, all amplitudes and frequencies of the output voltage of n units on each phase are identical, but there exists a phase difference of a certain angle (with a difference of $1/n$ switching period). Therefore, the phase voltage waveform generated by n units connected in series has $(2n + 1)$ levels. As a result, the harmonic content in the waveform is significantly reduced and the waveform is almost similar to a perfect sinusoid wave. The figure below shows the overlap waveform generated by 3 units connected in series and the load voltage and current waveform actually measured.

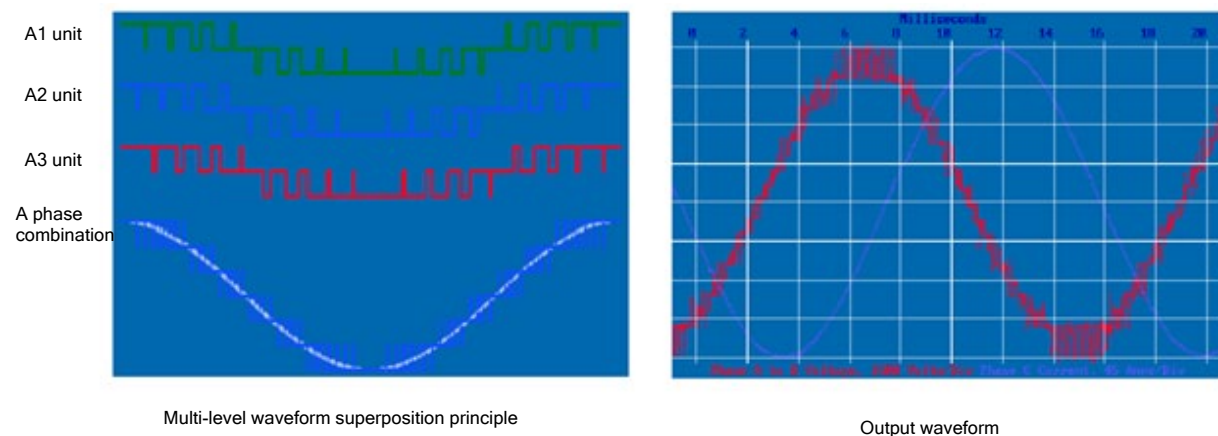

Internal structure of the power unit

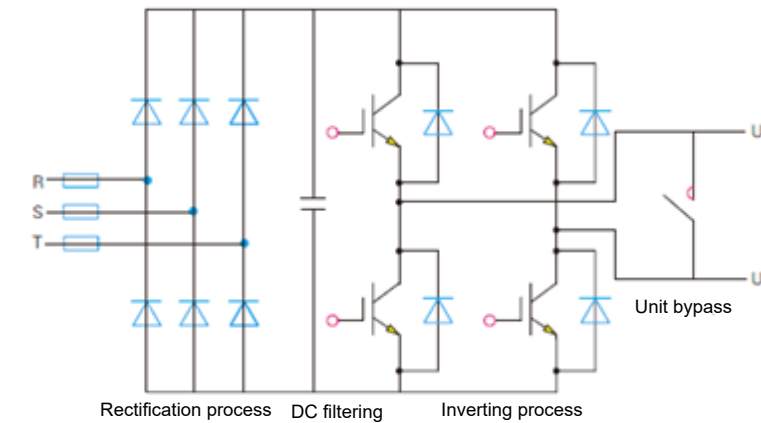

The internal structure of the power unit is shown in the figure above. The power input ends of R, S, and T are connected to the three-phase low voltage output ends of the secondary coil of a transformer. The three-phase diode full wave rectifier charges the DC link capacitor. The capacitor voltage is supplied to the single-phase H-bridge inverter circuit composed by IGBT.

Each inverter unit outputs the PWM sine wave. The multiple technologies are adopted in units connected in series. That is to say, all amplitudes and frequencies of the output voltage of n units on each phase are identical, but there exists a phase difference of a certain angle (with a difference of $1/n$ switching period). Therefore, the phase voltage waveform generated by n units connected in series has $(2n + 1)$ levels. As a result, the harmonic content in the waveform is significantly reduced and the waveform is almost similar to a perfect sinusoid wave. The figure below shows the overlap waveform generated by 3 units connected in series and the load voltage and current waveform actually measured.

External interface

The control system of HE1000 MVVFD is composed of a main control board, an interface controller board, and a touchscreen human-computer interface. A wiring diagram for all parts is shown below.

The built-in interface control board can perform logic and functions on the field I/O signals to enhance its flexibility in field application. An interface control board includes 11 DI inputs (dry nodes), 10 DO outputs (dry nodes, 250 VAC/1A), 4-way AI inputs (4-way, 4-20 mA), 3-way AO outputs (4-20 mA). The default 11 DI input functions and 10 DO output functions have been defined according to the application macro. The default functions can be modified before delivery of the equipment to meet the specific application requirements.

The interface controller board has the ability to deal with 4-way analog inputs and 3-way analog outputs. Analog inputs include the analog signals of flow, pressure, temperature, liquid level from the field and the set parameter signals. The output includes the electrical parameters of given analog quantities like frequency, current, voltage/exciting current. Meanwhile, the interface controller board can realize PID closed-loop control function and other functions for field application.

The interface controller board also provides a 1-way RS-485 communication interface, used for communication with a host computer or a peripheral control system following the MODBUS communication protocol. It also provides optional PROFIBUS-DP and Ethernet communication interfaces as well as optional client software like host computer monitoring software and Internet-based remote monitoring software.

Technical principle

Control system interface diagram

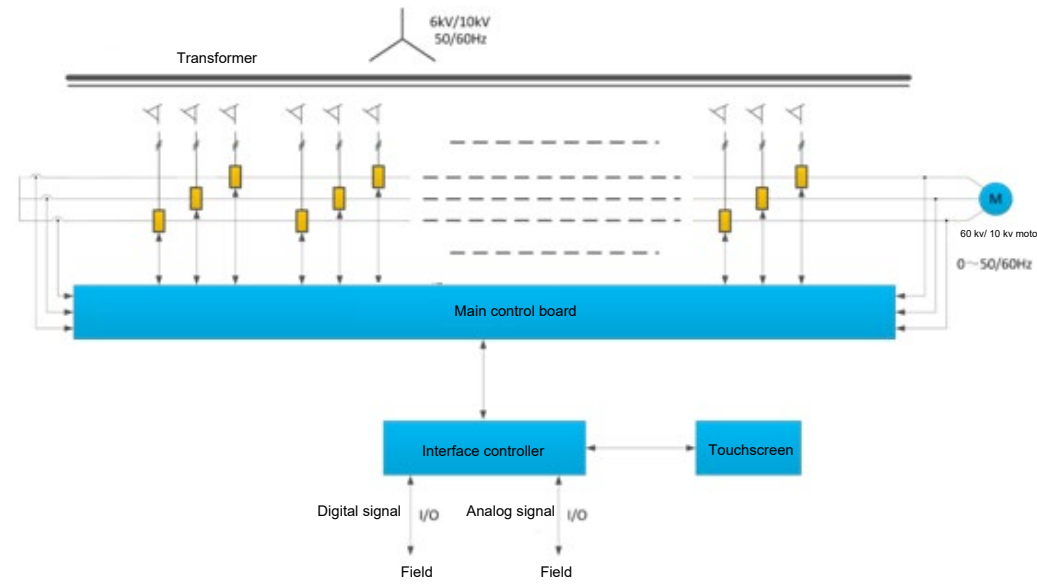

External interface diagram

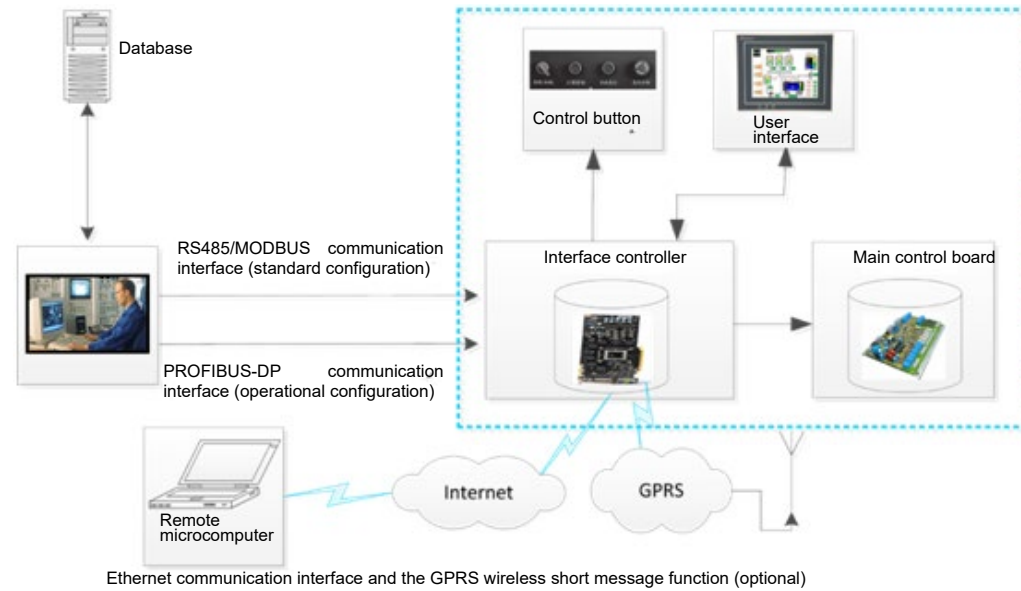

User interface

HE1000 MVVFD can be controlled from different places in the following several modes: Local control: Local control is combined by the direct control through a user interface and the cabinet control. Remote control: Remote control refers to the control through the start, stop, and giving of the input of an external terminal or a communication bus. The local control and remote control selector switch is located on the control board on the cabinet door. The user interface and operation button on the control board are shown in the figure below:

- Remote/local control selector switch; Fault resetting button
- Emergency stopping button
- Start/stop button
- Power light
- Running light
- Fault indicating light

HE1000 MVVFD is configured with a true-color and human-computer touchscreen interface (10 inches). It is a full Chinese operation interface, through which all operations on the MVVFD can be completed. The user interface can be locked and only authorized operators can access it and modify the parameters. Therefore, the operation security can be guaranteed.

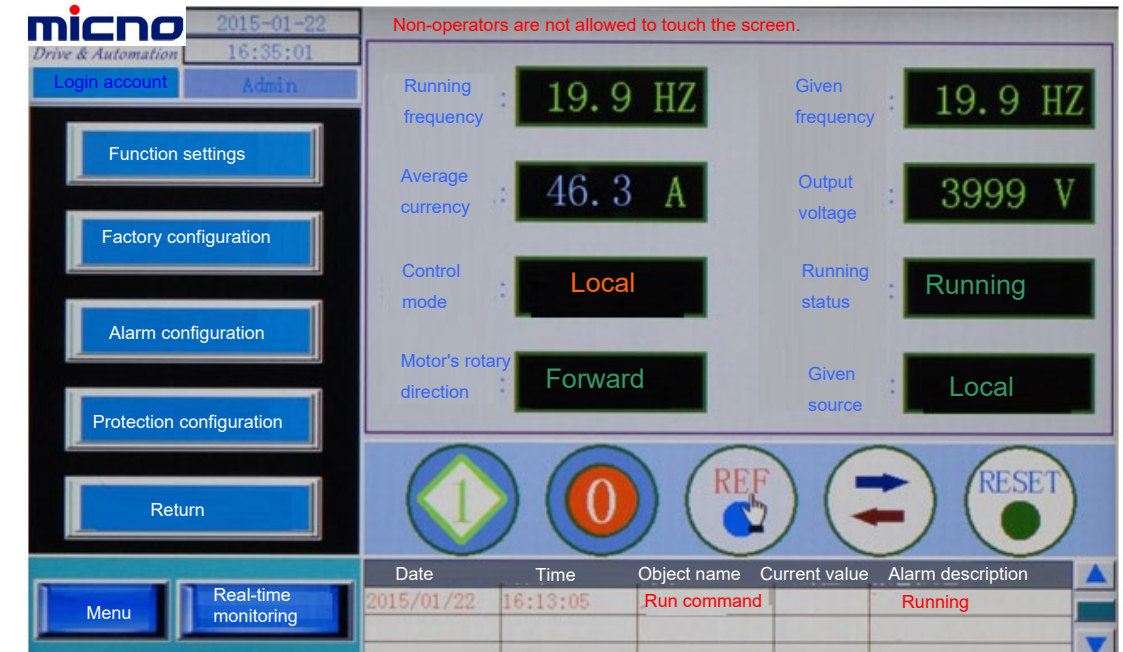

Control feature

HE1000 MVVFD is a line of products with high reliability for frequency conversion, speed adjustment, and energy conservation. With effective absorption of international leading technologies and in consideration of China's actual conditions, it is developed, designed, and produced by Shenzhen MICNO Electric Co., Ltd. based on years of cooperation with ABB, an international famous electric company, and its rich practical experience in the electric drive and the automation engineering application for almost 20 years. This product is characterized by Chinese operating system, high overload capacity, superb ability to adapt the power grid, and high starting torque. Therefore, it is more suitable to be applied in power grid and industrial equipment in China.

Control characteristics

By adopting the improved and perfected flux optimization and control with space vector PWM technology of the latest generation and in combination of state-of-the-art control theory, the control software is developed by a Germany R & D team on its own. The control precision of the dynamic rotational speed is lower than $\pm 2\%$ of the rated speed. The torque step response time < 10 ms. The output frequency resolution is up to 0.01 Hz.

High reliability design

High reliability and long service life

Reliability and stability shall be taken as the principle when selecting the models of core components. It is recommended that IGBT, rectifier bridge, driver module, capacitor, and optical fiber of internationally famous brands should be adopted. Sufficient safety surplus should be left when selecting the capacity to enhance overload capacity of the products and guarantee their reliability and long service life.

In terms of structure design, we absorb the leading design idea from the internationally famous brand companies like ABB, Siemens, and Robicon and adopt the mature and stable structure with multiple units connected in series. Also, we use a module design and make the standard unit have the auto bypass function to enhance the operation reliability of the products and thus significantly reduce the possibility of failure shutdown.

The designed service life is 20 years, designed MTBF is longer than 100 thousand hours, and designed MTTR is shorter than 10 minutes. Good heat dissipation and ventilation effect can be guaranteed as internationally famous brand cooling fans with long service life are installed on the top of the transformer cabinet, the inverter unit cabinet, and the control cabinet. The MTBF of the air cooling system is longer than that of the devices.

Infallible power supplied by the control power supply

The power for the system is supplied by a power supply controlled by double loops with standard configuration. (1-way internal loop of 220 VAC and 1-way external loop of 220 VAC). The internal control power supply is taken from an auxiliary secondary line winding of the input side isolation transformer. The control power supply will not lose power as long as the high voltage main power supply is active. When the high voltage main power supply loses power, the external power supply (220VAC) will maintain a supply.

The optional external control power supply (220 VDC or 110 VDC) input mode is specially designed for the direct power supply measuring and controlling system in a high-voltage power distribution room to obtain a stable control power supply from the DC system in a convenient way.

An optional UPS is available to obtain a more stable redundant power supply.

Control features

Optical fiber communication is adopted inside the VFD to realize the complete optoelectronic isolation and a good anti-interference performance.

Automatic current-limiting operation function

HE1000 MVVFD adopts the space vector and PWM control technology of the latest generation to realize the automatic torque limitation function. When the situation of abnormal load such as short-time high overload or short-time mechanical

jamming occurs abruptly, HE1000 MVVFD can automatically reduce the operating frequency, limit the output power, torque, and current, and maintain its operation to avoid overcurrent trip. After this phenomenon of abnormal load disappears in a short time, the VFD will return to normal operating frequency.

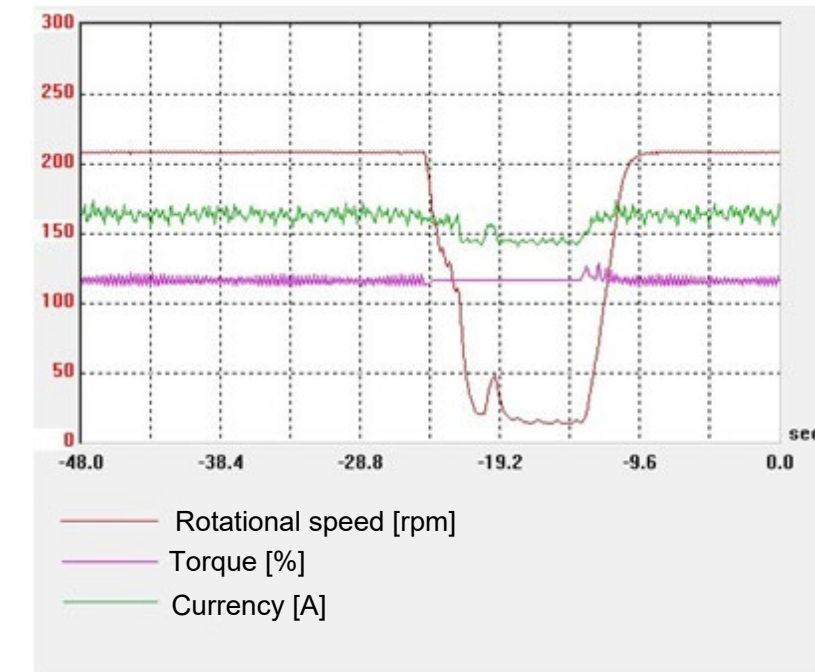

Power unit bypass operation

The entire HE1000 series feature hardware bypass operation for power units. When a power unit is faulty, this faulty power unit can be automatically switched to the bypass through the automatic bypass technology and the output three-phase voltage is automatically balanced for continuous operation of the VFD. At most 3-stage bypass function is offered. After the unit is switched to the bypass mode, the output can be adaptively regulated according to bypass stages and the current load to maintain a higher output power.

- ▲ A contactor is taken as the hardware bypass component for excellent anti-interference performance and greater security.
- ▲ The bypass and the inverter circuit work independently and thus have higher stability.

Perfect and reliable structure design

Electromagnetic shielding has been performed on the cabinet and the electromagnetic compatibility (EMC) meets stringent IEC1000-4 and IEC1800-3 requirements. The integrated design includes the dry-type transformer (H class insulation) with high reliability. The temperature of the iron core and windings of a phase-shifting transformer can be monitored. A threshold switch is designed on the transformer cabinet to ensure that the system will generate an alarm if the cabinet door is opened when the transformer is in operation. The heating equipment preventing condensation due to low temperature can be adopted to ensure that the transformer can operate in a cold and humid environment for a long time.

Surge absorption capacity for power protection

The entire HE1000 serial products have the surge absorption capacity for power protection which enables them to fully absorb the peak current for successful power-on at once. The surge absorption capacity for power protection of HE1000 includes the following two parts:

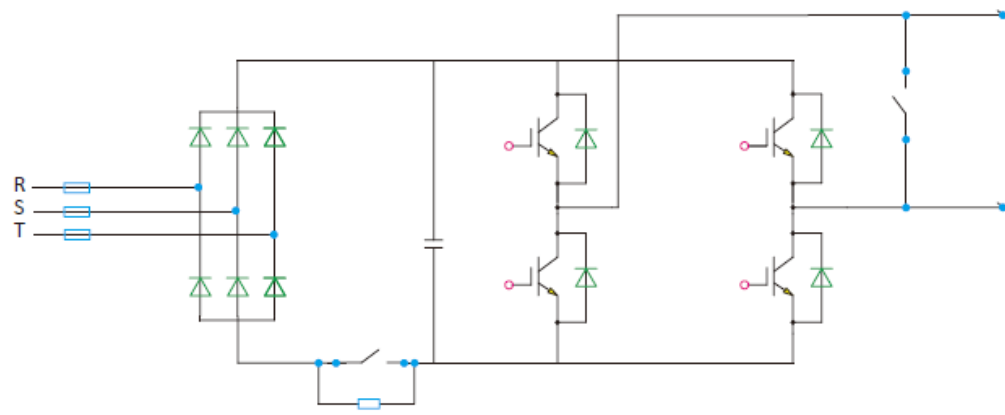

Anti-surge circuit for a unit

▲ Anti-surge measure for a unit

The input voltage of a power unit, through a fuse, enters a three-phase bridge rectifier for rectification, and then it is filtered by an electrolytic capacitor to become a direct current. To prevent the surge current upon power-on, a contactor and a resistor should be put in parallel, and then they should be connected in the middle of a three-phase bridge rectifier and a filter electrolytic capacitor in series. As a result, the electrolytic capacitor will be charged through a power resistor upon power-on. After the charging is finished, the contactor is sucked.

▲ Anti-surge measure for a system

The main circuit of a phase-shifting transformer is equipped with anti-surge resistors upon power-on and a vacuum contactor, which can effectively reduce the excitation inrush current and the electrolytic capacitor charging current at the moment of switching on, for a successful switch-on operation at once.

▲ High voltage surge arrester for surge protection

The input terminal of a high voltage power supply is equipped with a surge arrester, which can absorb a lightning surge and the surge formed by the switching overvoltage in the power grid.

Start with full torque at low speed

Benefiting from the leading "dynamic PWM" software, HE1000 MVVFD can operate stably at an extremely low frequency (approximately 0.1 Hz) with the widest range of speed regulation.

The starting torque of the VFD is adjustable. When starting a overloaded device, like a belt conveyor, a roller mill, or a draught fan suffering from jamming due to a seriously corroded bearing shell, the VFD can output an extremely large starting torque at an extremely low operating frequency (approximately 0.1 Hz) to ensure a normal start of a load.

HE1000 MVVFD is a high-performance VFD which is not only suitable for variable torque loads, but also suitable for constant torque loads.

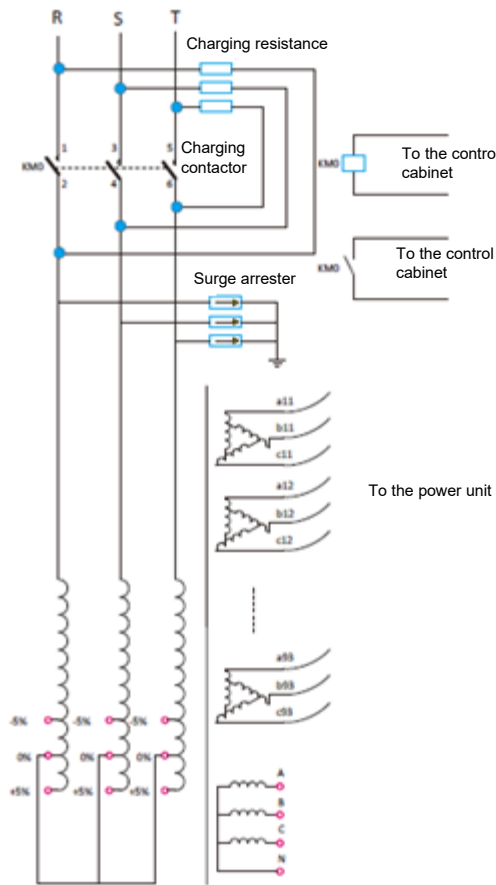

Anti-surge circuit diagram for a system

Starting a motor inversely rotating at a low speed

Benefiting from its excellent features, HE1000 MVVFD has the function of "starting a motor inversely rotating at a low speed". It adopts a technology equivalent to the DC braking (DC brake) when starting a motor inversely rotating at a low speed. First, it slows the speed of a motor inversely rotating at a low speed down to zero, and then make the motor run from zero speed. The function of "starting a motor rotating inversely at a low speed" allows the MVVFD to start a motor rotating inversely in a safety mode without current trip.

Restart with speed tracking (Flying restart)

HE1000 MVVFD adopts the unique "slip current control algorithm" to automatically search and recognize the motor rotating speed. It starts the rotary electric motor at current speed rather than the zero speed for a safe startup at a low current. Therefore, it reduces the impact on the power grid and weakens the influence on production when an immediate outage occurs.

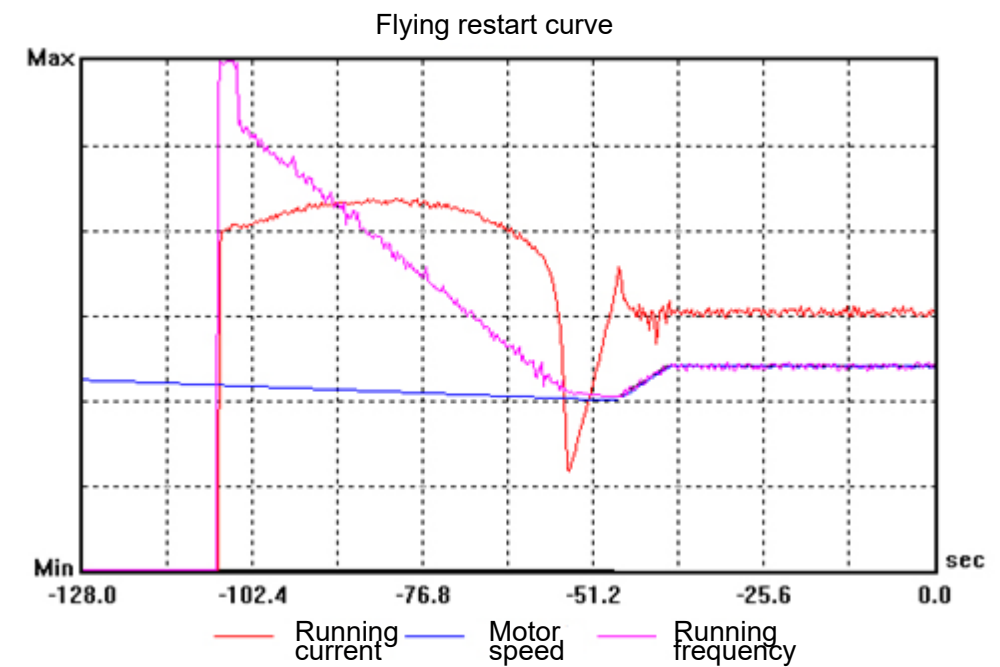

Excellent input side features

For 6 kV devices: 30/36 impulse input.

For 10 kV devices: 48/54 impulse input.

The grid-side harmonic is low. No need to install the noise filter. The input harmonic content can meet the requirements of IEEE 519-1992 and GB/T14549-2002.

The power factor exceeds 0.97 at rated load in the range of normal speed regulation.

The blue curve and yellow curve in the diagram refers to the input current curve and the input voltage curve respectively. Both waveforms are close to the sine wave, with negligible harmonic content.

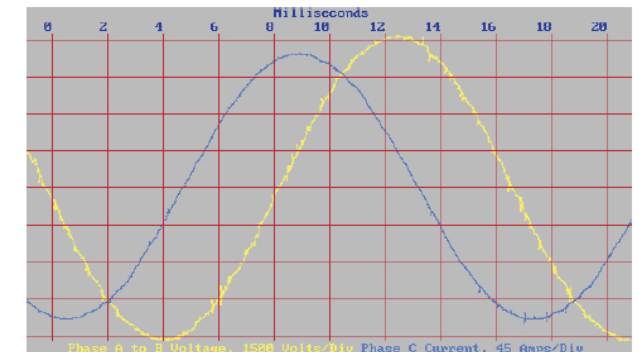

Control feature

Excellent output features

The HE1000 MVVFD can output excellent multi-level PWM sine waves. A 6 kV MVVFD can output an 11- or 13-level phase voltage, and a 21- or 25-level line voltage; a 10 kV MVVFD can output a 17- or 19-level phase voltage, and 33- or 37-level line voltage. It has a small dt/dv value, and the output voltage and current waves are near perfect sine waves. It has no special requirements to the driven motor and can drive motors made in China.

Common power cables can be adopted as input and output cables. The output cable stretches as long as 1,500 m (inform Micno in advance if you need a longer cable). The HE1000 MVVFD can operate stably with small output voltage and current harmonics, small motor torque ripple, and low noises.

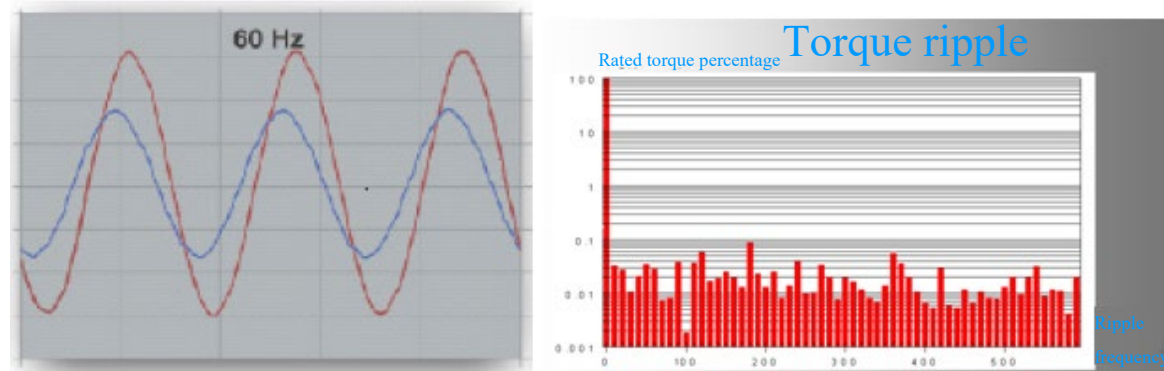

Complete fault handling functions

With its complete fault diagnosis, location, and handling functions, the HE1000 MVVFD categorizes and handles faults based on severities, outputs the fault and content in real time, and record the fault in the log.

The HE1000 MVVFD also has a series of complete protection functions for MVVFD overheat, input overvoltage, input undervoltage, output overcurrent, motor overload, output grounding, output short-circuiting, equipment overload, power unit fault, cooling fan fault, and interlocking of doors to the high voltage switchgear. Some fault can intertrip the high voltage switchgear on the input side.

Powerful adaptive feature to the voltage fluctuation of power grid

HE1000 MVVFD can operate at full load when the power grid voltage ranges from -20% to 15%

HE1000 MVVFD can continue to operate at a derated load with decrease of the power grid voltage by 35%

Power loss ride-through and power failure recovery features

HE1000 MVVFD can maintain a normal operation within 10 cycles after immediate power outage. A longer power outage duration is allowed when HE1000 MVVFD operates under light load.

When VFD loses power for a period longer than 10 cycles, it will automatically operate at a derated load. The VFD will shut down when the power outage duration exceeds 10 seconds.

When the power is transmitted again by the power grid, it is recommended that the HE1000 MVVFD should be re-started after the automatic speed tracking is set based on the requirements.

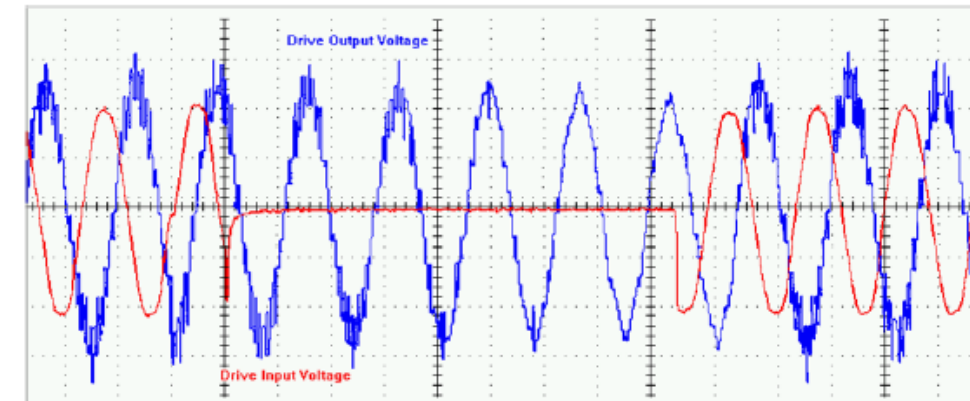

Reliable redundancy control feature

The core control part of HE1000 MVVFD is designed by two control systems adopting PLC and touchscreen based on the DSP control board, which is a dual redundancy control mode. The PLC system is taken as the external interface, realizing a transition from the external control port to the internal DSP control board. The external port is completely isolated from the internal control board. This not only significantly enhances the reliability and anti-interference ability of the system to avoid interference on the control part of the VFD from an external system, but also is conducive to the upgrade and maintenance of the system and addition of the monitoring function. The design is more reliable when compared with the design of adopting only a single chip control board adopted by most similar manufactures in China.

Safe resonance avoidance

HE1000 MVVFD allows users to configure three sets of resonance frequency hopping points to effectively avoid mechanical resonance of the electromechanical system and thus to ensure the safe and reliable operation of the drive system.

Automatic flux optimization

HE1000 MVVFD adopts the exclusive flux optimization technology which enables real-time monitoring and flux optimization on the entire speed regulation system including the motors, and thus increases the system efficiency by 1% to 10% and save more energy than a similar VFD does.

The automatic flux optimization also facilitates reduced operating current of the motor and improved stability of the device. Current motors are made based on the power frequency design patterns. When some motors are running at a variable frequency, the best magnetic intensity rather than rated magnetic intensity may occur at a particular frequency (especially within the medium or low frequency range), which may cause large operating current and unstable operation if the traditional vector control strategy is adopted. In this case, MVVFD will enable automatic flux optimization in combination of the space vector PWM control algorithm to adjust the motor flux to the specification value of the motor, reduce the operating current of the motor and improve the stability of the system.

Large capacity design

The designed power of 10 kV and 6kV MVVFDs is 20,000 kW, 6 kV and 12,000 kW respectively. Tens of synchronous/asynchronous motors with high power above 5,000 kW have enjoyed success in many applications.

Power bypass

The HE1000 MVVFD provides multiple power bypass operation models that can help ensure uninterrupted production upon fault handling or inspection.

Bypass mode

Bypass mode can be provided based on practical requirements. The following figures show the common bypass modes.

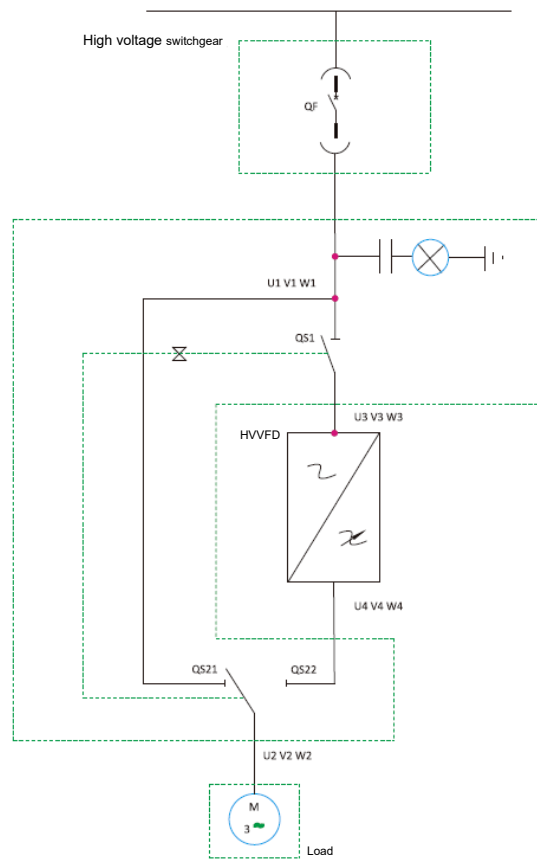

Manual one-drive-one bypass

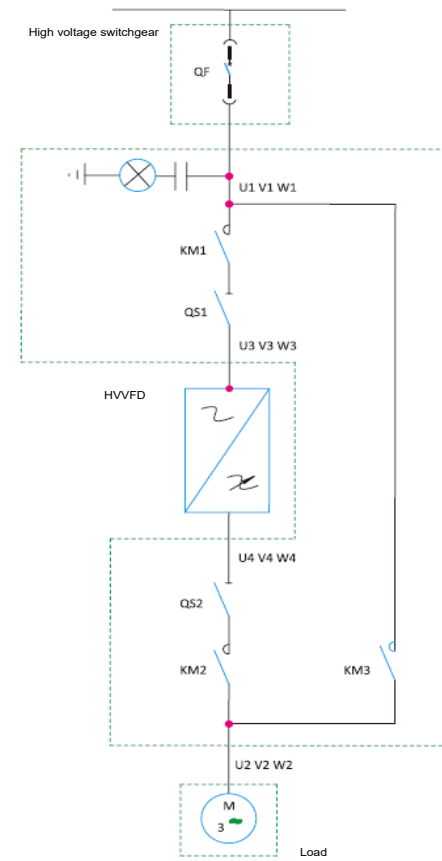

Automatic one-drive-one bypass

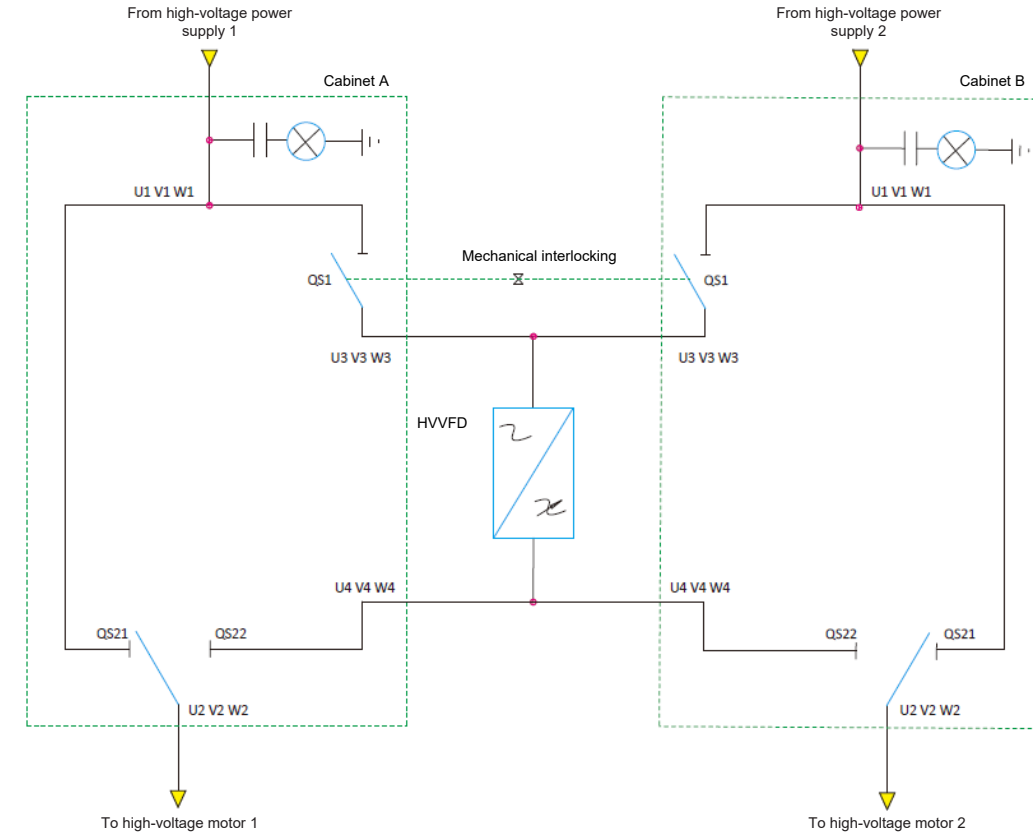

Manual one-drive-two bypass diagram

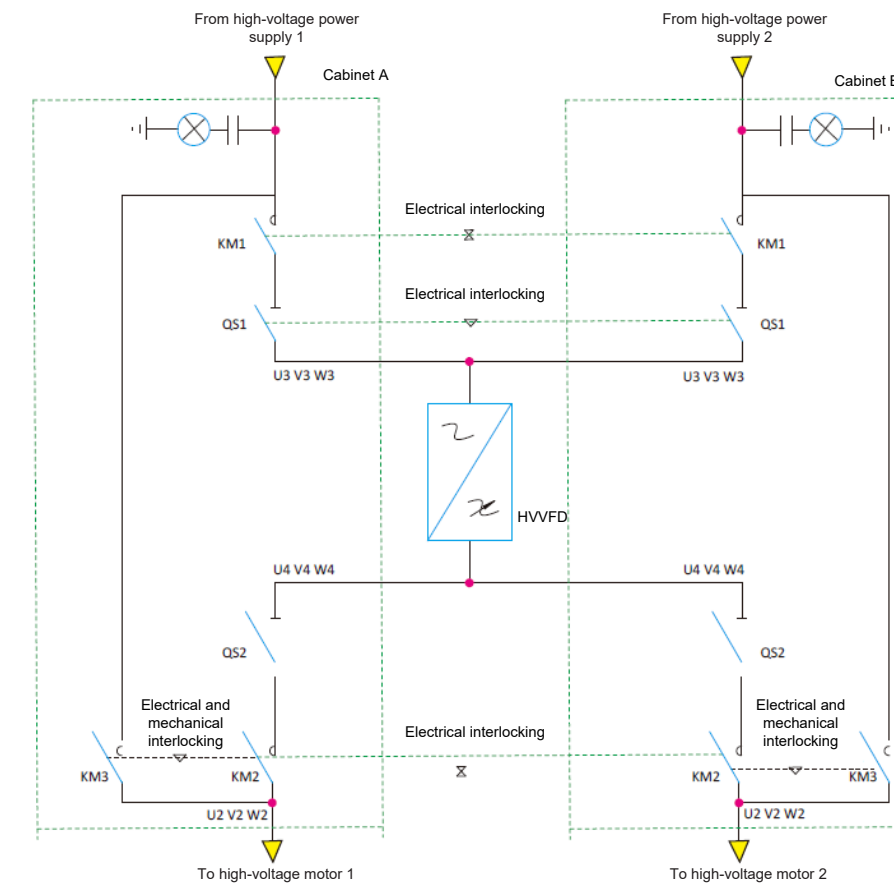

Automatic one-drive-two bypass diagram

HE1000A General MVVFD for Asynchronous Motors

The HE1000A general MVVFD for asynchronous motors is applicable to loads such as fans, pumps, air compressors that are driven by asynchronous motors. As most of these loads are directly driven by motors, with large installed capacity, and play a key role in the overall operating process, an equipped MVVFD for these loads should be reliable, adaptive to different power grids, with successive startup function, favorable speed-adjustment performance, energy-saving, and easy to maintain. For an equipment upgrading project in particular, an MVVFD should meet the requirements for installation in specific space and can drive general motors or be used for long-distance output. With its excellent low-speed and high torque, the HE1000A general MVVFD is also applicable to large loads with constant torque such as Roots blowers, rotary screw compressors, grinders, rubber mixing mills, and crushers that need to be started with heavy loads.

By adopting the world's leading control technology, highly-reliable hardware, and advanced heat dissipation structure, the HE1000A general MVVFD features premium performance, better energy-saving performance, easier installation and application, longer lifespan, and requires lower maintenance fees. It meets the application requirements for different fields, and has been widely applied in many projects in China and other countries.

Main applications

Power industry: feedwater pumps, primary fans, air blowers, exhaust fans, mortar pumps, recirculation pumps, and booster pumps



Metallurgical industry: mud pumps, inducer fans, ventilation fans, dust blowers, centrifugal feed pumps, and boiler blowers



Petrochemical industry: water injection pumps, inducer pumps, extrusion pumps, electrical submersible pumps, main pipe pumps, gas compression pumps, and boiler water supply pumps



Water treatment industry: purification pumps, freshwater pumps, booster pumps, and sewage pumps



Cement industry: high-temperature fans, cave tail exhaust fans, circulation fans, coal mill ventilation fans, and exhaust fans



Non-ferrous metal industry: ID fans, mother liquor pumps, seed pumps, underflow pumps, overflow pumps, feed pumps, and roots blowers

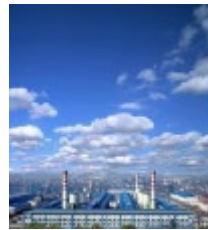

Coal chemical industry: boiler blowers, inducer fans, water feeding pumps, condensate pumps, Slag-flush pumps, and mortar pumps



Wood manufacturing industry: circulation fans, dry blowers, and inducer fans



Mining industry: main fans, water discharge pumps, medium pumps, crushers, and grinders



HE1000A General MVVFD for Synchronous Motors

As AC synchronous motors perform better in terms of operating efficiency, power factor, and power density, such motors are commonly applied to high capacity loads such as air compressors, fans, pumps, elevators, and rolling mills.

The HE1000A general MVVFD for synchronous motors applies the dedicated new flux optimization and control with space vector pulse-width modulation (SVPWM), and resolves problems such as high startup current, and asynchronous vibration or vibration for startup and speed adjustment with heavy loads. It supports precise rotational speed, torque, and excitation control, and features better energy-saving performance and reliability. It's applications in large power synchronous motors have reached a world leading level.

Type of driving loads

- ▲ Permanent magnet synchronous motor
- ▲ Exciter synchronous motor with brushes
- ▲ Brushless exciter synchronous motor

Excitation control model

- ▲ Automatic excitation adjustment of the VFD
- ▲ Automatic multi-segment excitation adjustment of the VFD
- ▲ Automatic external excitation adjustment
- ▲ Manual external excitation adjustment

More functions

- ▲ Excitation devices
- ▲ Higher-level control system
- ▲ Power-saving analysis software
- ▲ Remote automatic meter reading system

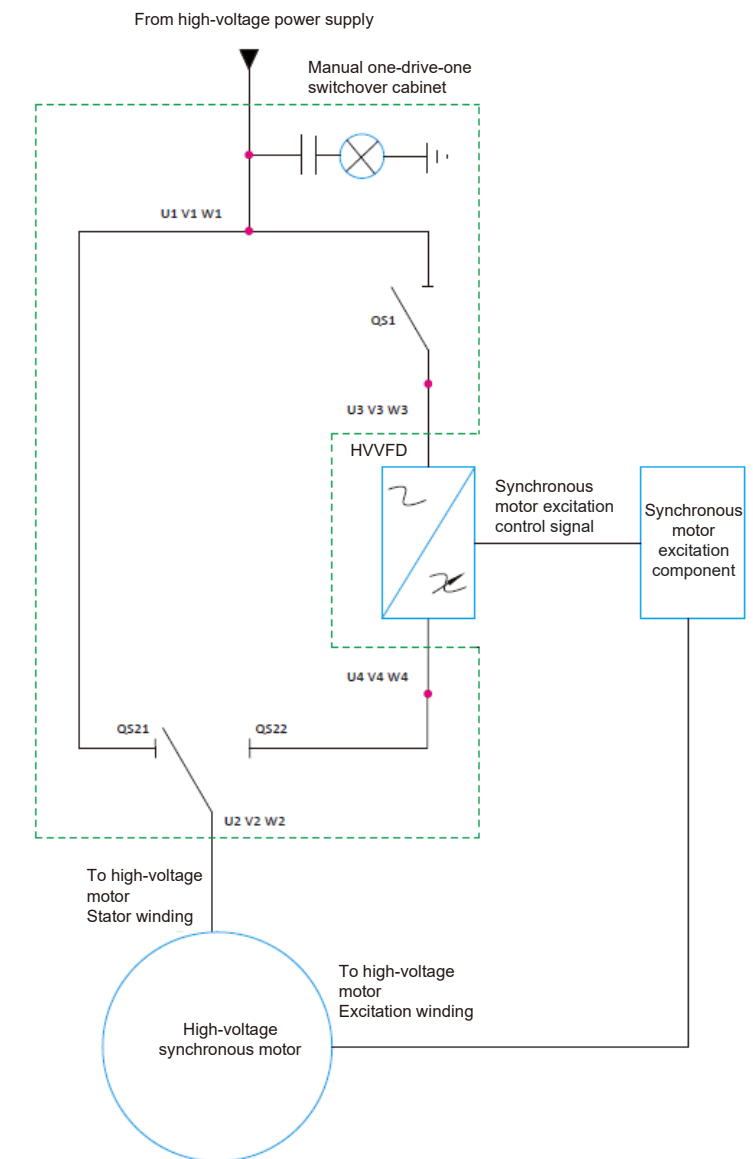

HE1000B/D Belt Conveyor MVVFD

The HE1000B/D belt conveyor MVVFD is based on the topological structure of power units developed by Micno. It is used to control the speeds of single-drive, double-drive, three-drive, and four-drive belt conveyors.

The main circuit structure of the HE1000B/D belt conveyor MVVFD is similar to that of the HE1000A/S general MVVFD, but the former one is with higher hardware configurations, and a dedicated control function is also added to the software, which meets the specific operation requirements for belt conveyors.

Heavy load configurations, large starting torque

Belt conveyors require large startup torque and are fluctuant when operating with loads. The HE1000B/D belt conveyor MVVFD adopts the heavy load components, and it can be operated at 1.6 times or greater of the rated current for 1 min. When being started with load at a low speed, its starting torque can be as high as 160% or greater. You can select the configuration with greater torque based on the heavy load startup requirements under different working conditions.

A standard HE1000B/D belt conveyor MVVFD is not configured with four quadrants and adapts to horizontal or upward belt conveyor applications. In a downward belt conveyor application, the spare parts for four quadrants can be added to meet the power generation requirements for the belt conveyor.

Harrison curve control

The HE1000B/D belt conveyor MVVFD adopts the Harrison control during startup, shutdown, speed-up, and slowdown, which ensures the stability of the speed-up and slowdown process. It controls the startup and shutdown of a belt conveyor by separately controlling the head and tail in different time, thereby avoiding great tensile waves generated during startup, protecting the security of electrical and mechanical equipment, lowering the damage to equipment, and reducing maintenance fees.

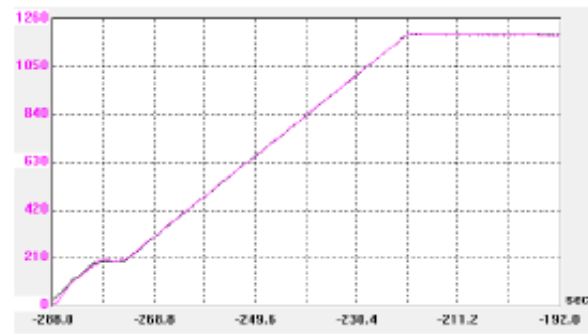

--Conveyor head rotational speed; --Conveyor tail rotational speed

Low-speed, large torque output

The HE1000B/D belt conveyor MVVFD can output a rated torque of greater than 160%, which enables inspection of belt at low speed, and meet the requirements such as commissioning and maintenance.

Balance control for operation with multiple loads

The HE1000B/D belt conveyor MVVFD adopts the master-slave VFD synchronous control technology that allows the MVVFD to communicate through optical fibers internally, and integrates multidrive frequency control systems into a control system. The operating status of the conveyor is automatically controlled by the HE1000-JX belt conveyor centralized control box. In this way, the torque, power, current, and speed of each conveyor system will be synchronized, and the belt conveyor can operate properly without generating equipment faults caused by drive imbalances.

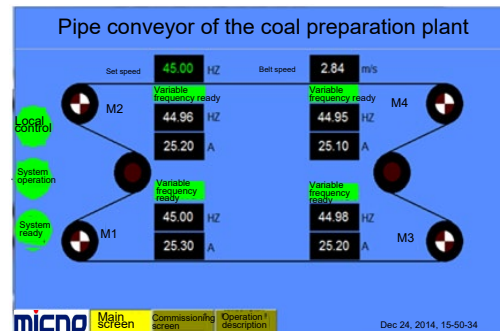
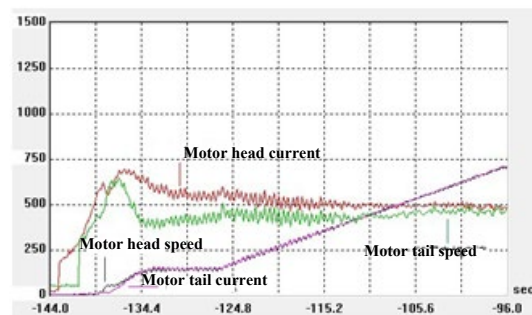

Belt conveyor main control system (optional)

- ▲ Multi-motor interlock startup and shutdown
- ▲ Signal system
- ▲ Belt conveyor protection
- ▲ Conveyor head and tail startup and shutdown sequences
- ▲ Upper computer monitoring

Multidrive system diagram

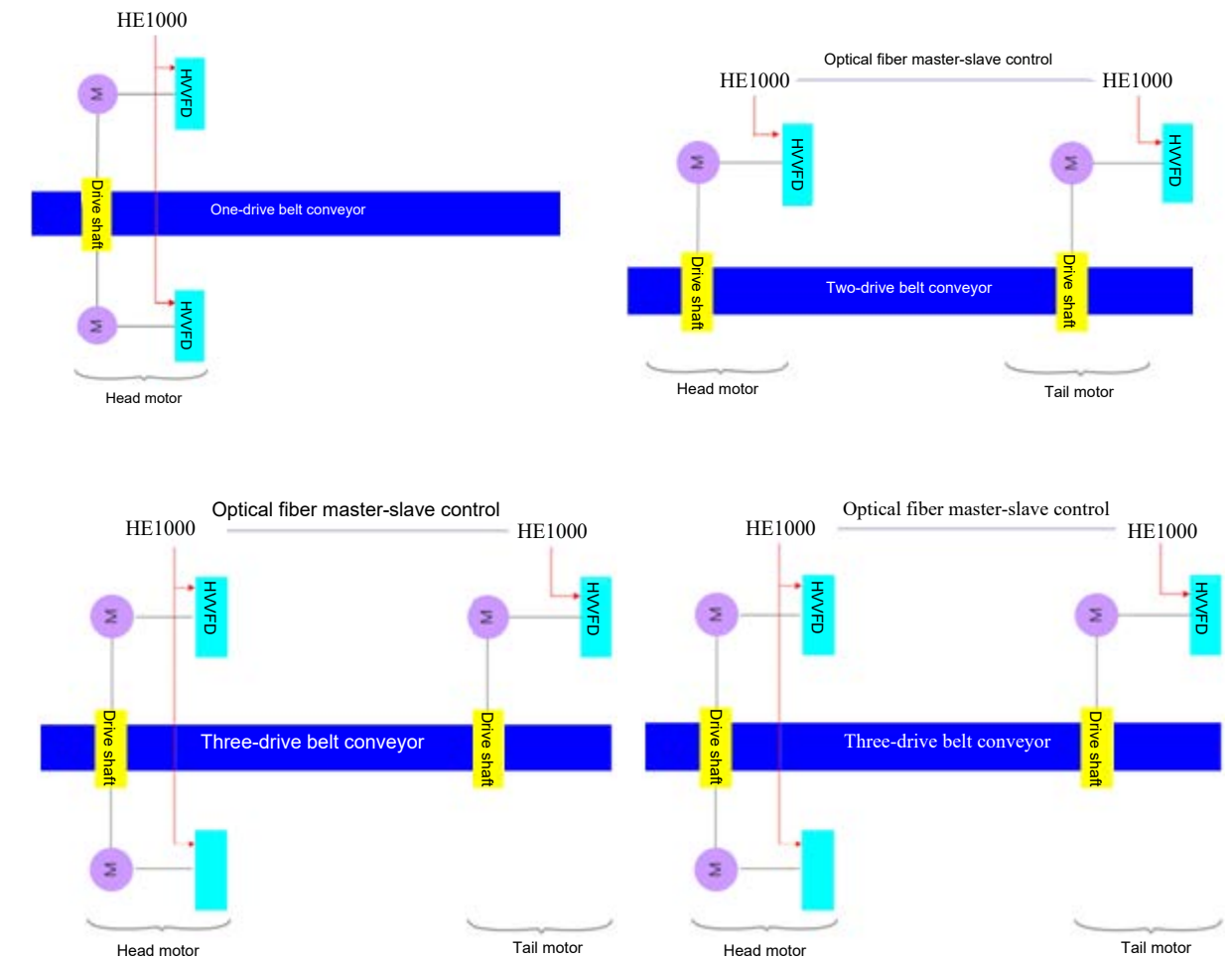

Applications

- ▲ Belt conveyors, belt conveyers, conveyors
- ▲ Rubber mixing mills, injection molding machines, plastic extruders
- ▲ High pressure roller mills, ball mills, crushers
- ▲ Zipper machines, scraper
- ▲ Other multidrive loads

HE1000P/Q Synchronous Undisturbed Switching Softstart MVVFD

System composition

The core equipment of the HE1000P/Q synchronous undisturbed switching softstart MVVFD is the HE1000A/S MVVFD whose software has been upgraded. The HE1000P/Q integrates peripheral equipment such as the reactor, switchover cabinet, and inspection and control systems for synchronous switchover to a basic MVVFD to form a complete set of synchronous switchover softstart MVVFD. The system consists of the following parts:

1. HE1000A/S MVVFD
2. TQ series synchronous undisturbed switching control board
3. GTA2-II series high voltage reactor cabinet
4. PLG-AQ series synchronous inspection and switchover control system
5. GP series power frequency switchover cabinet

Working principle

In the case of an one-drive-one synchronous undisturbed switching softstart MVVFD, when the motor is started and the output disconnecter and circuit breaker are closed, the MVVFD begins to drive the motor. The output frequency of the MVVFD increases from 0 Hz to 50 Hz (the duration can be set), and the output voltage begins to increase from 0 V to 0.6/10 kV. The motor begins to operate at a rated rotational speed.

After the output frequency of the MVVFD reaches 50 Hz and the grid integration command is received, the MVVFD adjusts the output voltage to the same level as the input voltage of the grid. After the system detects that the frequency, phase, and amplitude between the output voltage of the MVVFD and the input voltage of the grid are the same, the circuit breaker for the motor frequency power will be closed. At this time, the motor is powered by both the MVVFD and grid, and the current of the motor is transferred to the grid through the MVVFD. The system then disconnects from KM2, and the motor is powered by the grid. The startup of the motor has been completed by this step. The contactor KM1 is disconnected and the MVVFD stops working.

Features

- ▲ Precision inspection system
- ▲ Synchronous control and intelligent synchronous point decision algorithm
- ▲ Softstart of motor, startup current smaller than rated current
- ▲ Undisturbed switching with a transfer current less than the rated current
- ▲ Unlimited startup times
- ▲ Low requirements on grid; powered by either mains, captive power generation plant, or diesel engine; adaptive to applications with large loads and small grid automatic operation, low maintenance requirements
- ▲ One for multiple (one-drive-one, one-drive-two, one-drive-multiple)
- ▲ Multi-frequency mutual backup (two-drive-two, two-drive-three)
- ▲ Securest and most reliable undisturbed switching in industry

Applications

- ▲ Soft-start variable frequency drive for high-power fans
- ▲ Soft-start variable frequency drive for high-power air compressors
- ▲ Small-current soft starter for fans and air compressors powered by power generators
- ▲ Dual-frequency mutual backup of two-drive-two operation for key process equipment (two-drive-two variable frequency operation for main sintering fans)
- ▲ Other applications requiring variable-frequency soft start and synchronous undisturbed switching

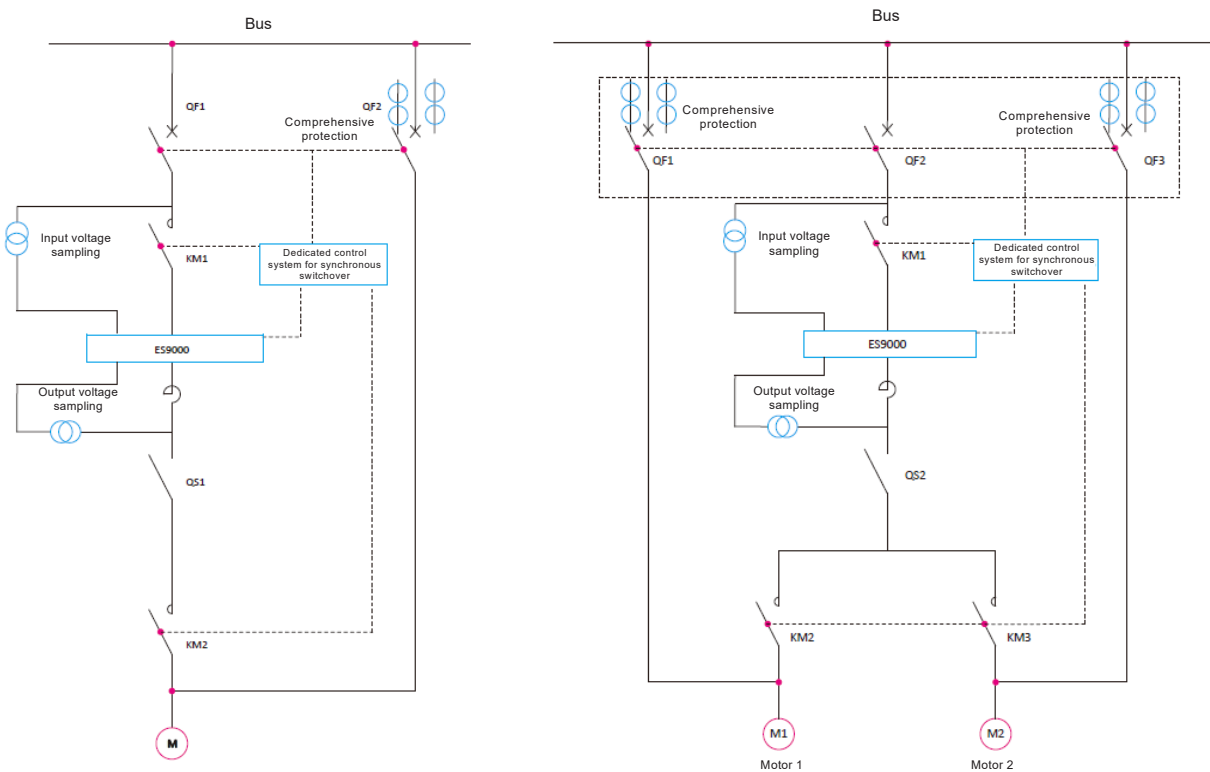

One-drive-one synchronous switchover softstart MVVFD

One-drive-two synchronous switchover softstart MVVFD

Dedicated product series

HE1000F/G Four-Quadrant MVVFD

The HE1000F/G four-quadrant MVVFD is based on the topology of power units in series and supports bidirectional power flow. By using the HE1000F/G four-quadrant MVVFD, either the electrical energy can be transferred to mechanical energy for driving the loads, or the mechanical energy generated by loads can be transferred to electrical energy to the grid, which can save the energy at a great extent.

The main circuit of the HE1000F/G four-quadrant MVVFD is similar with that of the HE1000A/S general MVVFD, but the power unit and control technology of the former are uniquely designed.

Composition of the power unit

The power unit consists of the power distribution component, rectifier, energy storage component, feedback, inverter, feedback current detection, and filter feedback. Beside the general inverter control and bypass control functions, the power unit of the HE1000F/G four-quadrant MVVFD supports the grid feedback and filter functions, which enables four-quadrant operation by allowing bidirectional power flow between the input and output power. The harmonic can also be effectively controlled in this way.

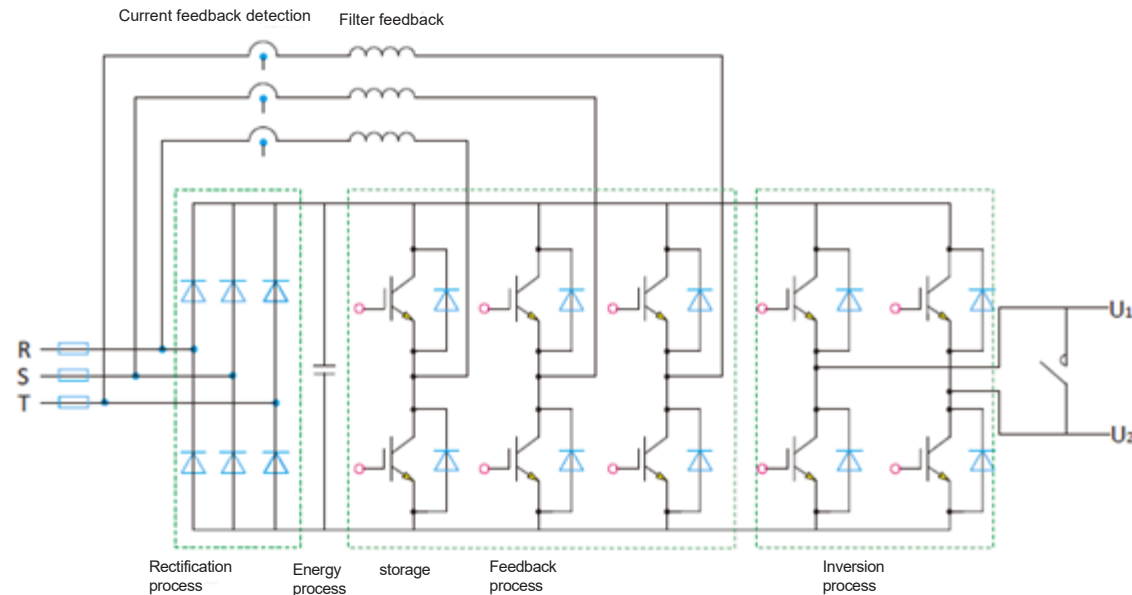

Main control features

- ▲ Optimum performance in dynamic and stable status with the flux optimization and control with space vector PWM technology, power factor in the power grid side around 1.0
- ▲ Premium energy-saving technology with the unique voltage monitoring technology for power unit bus
- ▲ Higher security level with independent feedback process and rectifier process of the MVVFD power unit
- ▲ Favorable heat dissipation and stability with a more reasonable and even distribution of power-consumption components
- ▲ Pollution-free to the grid with perfect feedback current sine wave
- ▲ Reactor added in the feedback filtering process; high heat dissipation efficiency with favorable ventilation design
- ▲ Convenient maintenance with modular design for the power units

Typical application

- ▲ Motor load simulation test
- ▲ Downward belt conveyor
- ▲ Mine hoister, winch
- ▲ Crane, gantry crane, tower crane

Standard cabling diagram

The terminal function of the HE1000 MVVFD are defined by application macro, a specific software function. Such software corresponds with the terminal diagram and provides a specific control function for convenient user design and onsite cabling. Customers can commission the application macro on site by selecting the configurations, which is very convenient. For different application macros, the definitions of digital input (DI) and analog input (AI) differ a little bit, but those of digital output (DO) and analog output (AO) remain the same. For detailed definitions of application macros, see the HE1000 High Voltage Variable Frequency Drive User Manual.

The application macros for the HE1000 MVVFD are as follows:

- ▲ Factory macro: for most of the industrial fields (factory macros are also the default application macro before factory delivery)
- ▲ Three-phase control macro: apply to the control logic that is controlled by buttons
- ▲ Manual and auto macros: apply to local and remote switchover control
- ▲ PID macro: apply to closed-loop control
- ▲ Multi-speed macro: apply to constant speed operations with different grades
- ▲ Motor potentiometer macro: apply to scenarios without specific simulation speed but requiring variable speeds

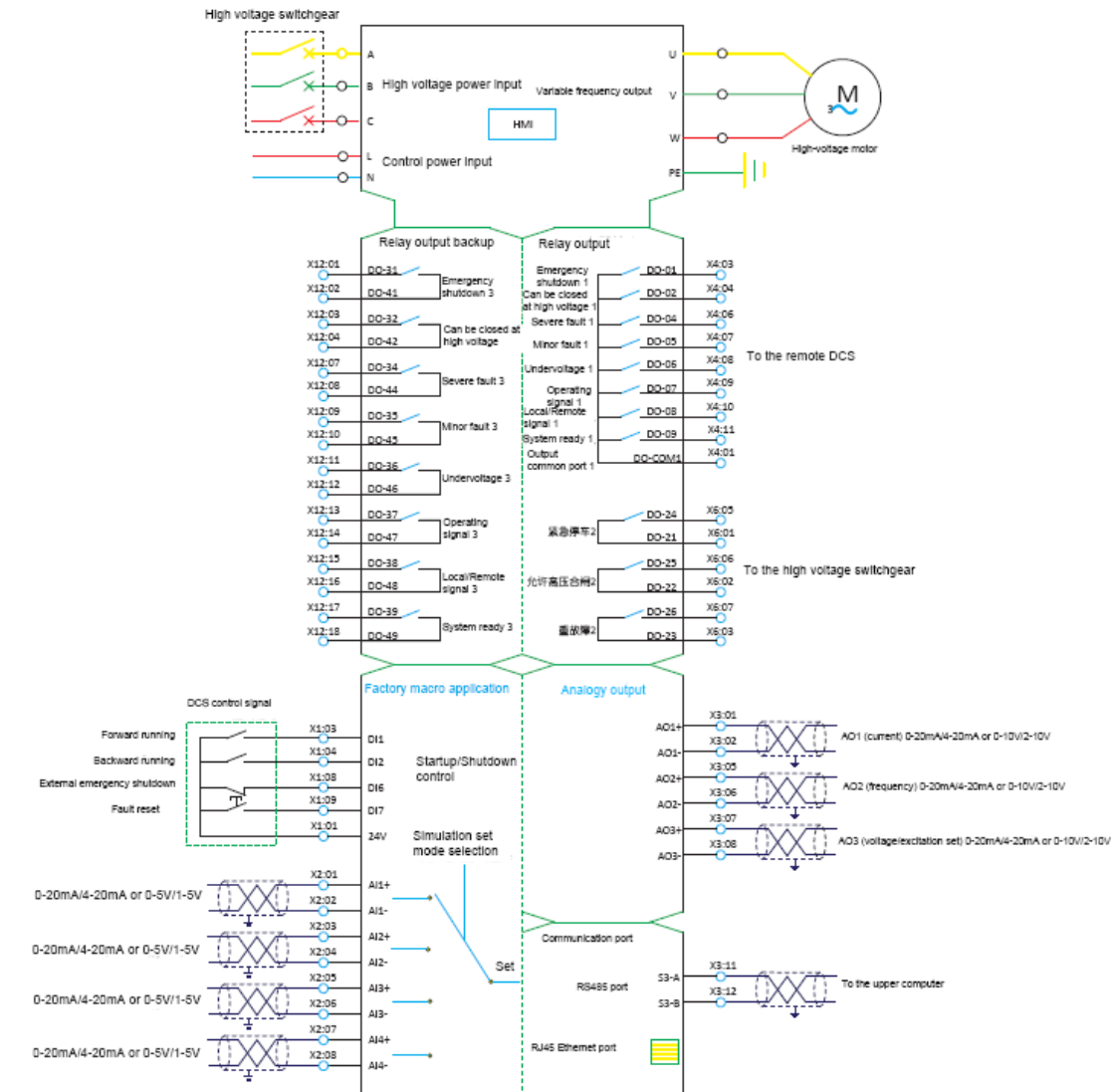

Installation and use requirements

Requirements to Installation Foundation

Installation requirements: All the cabinets should be secured to the installation supports, and reliably connected to the steel structure of the plant and the grounding system. Cabinets and ground terminals should be connected to the general ground bar of the plant, and the ground resistance should be not greater than 4 ohms. Cabinets are secured to beams as an integral part using M10 screws.

Requirements to foundations

- ▲ The foundation of the MVVFD must be soldered using the 14b# steel channels. The installation surfaces must be level and 2 mm to 5 mm over the ground.
- ▲ Ensure the installation quality of the basic frame. The tolerance for each meter is 1 mm.
- ▲ The steel channel for the 14b# support should be soldered to the embedded support plate.
- ▲ The equipment should be soldered to the basic steel channels.
- ▲ The trench should be waterproof, dustproof, and rodentproof.
- ▲ The depth of the trench is decided by the customer.

Top view of the installation foundation

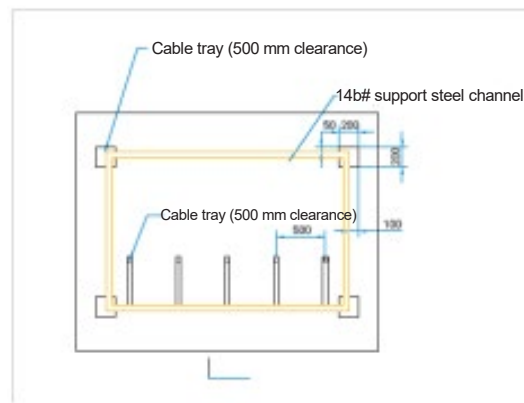

Top view of the installation foundation

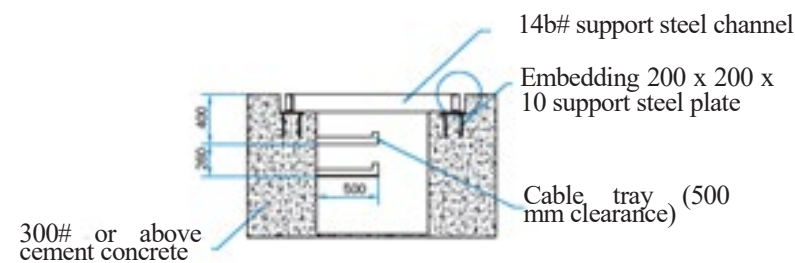

Partial view of the installation foundation

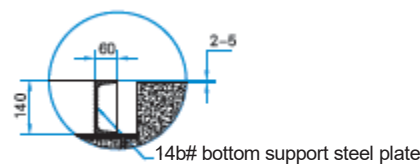

Requirements for Operating Environments

Ambient: not exposed to the sun, no corrosive or flammable gas, no conductive dust, water drop, salt, dust, or vibration

Operating altitude: < 1000 m, derated when the altitude is greater than 1000 m

Operating temperature: 0°C to 40 °C

Humidity: < 90%, non-condensing

Operating environment: indoor

Three recommended cooling methods (MVVFD cooling methods)

Air duct cooling: Such cooling method is applicable to the installation site of no hazardous substances such as explosive or corrosive gas, conductive dust, or oil mist. Such application is cost-effective by using air ducts for heat dissipation. An air intake vent and filter should be installed for the MVVFD room, and other parts of the MVVFD room should be sealed. Water intrusion protection and rodentproof measures should be applied to the air outtake vent. To ensure the long-term reliability and lifespan of the MVVFD, sufficient power for heat exchange should be reserved. The power is recommended to be 4% of the MVVFD rated power. In such application, the air discharge volume of per 10 kW power loss should not be higher than 1 m²/s.

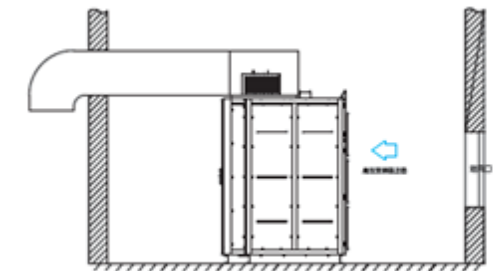

Air duct cooling schematic diagram

Air conditioner cooling: Such cooling method applies to the environment with hazardous substances such as explosive or corrosive gas, conductive dust, or oil mist, poor ventilation conditions, and high cooling requirements. In such application, the MVVFD room should be completely sealed and cannot be applied together with the air duct cooling method. To ensure the long-term reliability and

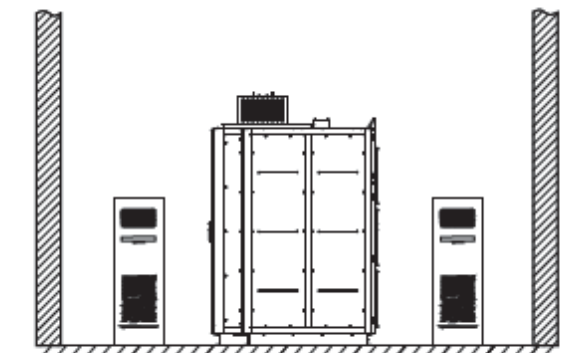

Air conditioner cooling schematic diagram

lifespan of the MVVFD, sufficient power for heat exchange should be reserved. The power is recommended to be 4% of the MVVFD rated power. In such application, at least a 4 P (around 3 kW) air conditioner should be equipped for per 10 kW power loss.

Heat exchanger cooling: Such cooling method applies to the heat dissipation of large power VFDs. It meets the requirements of application with large heat dissipation amount and high requirements. Different models are applied based on practical application environment. If detailed information, please consult the technical personnel of Micno.

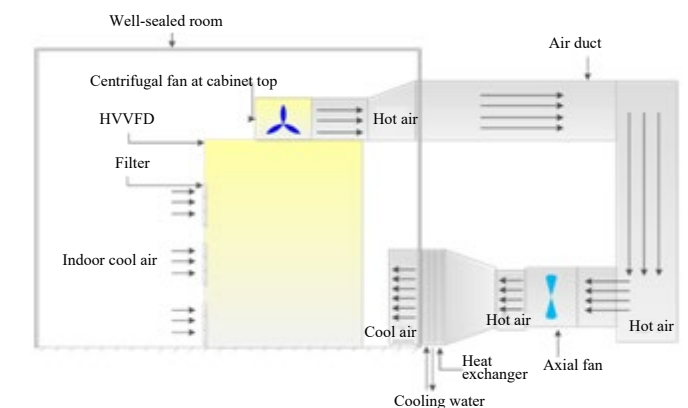

Storage, transportation, and hoisting

Storage requirements

The operating temperature ranges from 0°C to 40°C, and the storage temperature ranges from -40°C to 70°C. As the lifespan and reliability of the MVVFD is greatly affected by the environment, do not install your equipment in environment that does not meet the proceeding conditions. If the installation environment exceed the allowed range, enhance the ventilation or use the air conditioner cooling method to ensure that the environment is within the allowed range. Do not store the MVVFD in the environment with:

- ▲ Exposure to the sun
- ▲ Corrosive gas
- ▲ Flammable and combustible gas
- ▲ Conductive dust
- ▲ Moisture that may cause condensation
- ▲ salt, oil mist, and dust

Transportation requirements

1. Ambient requirement: IEC 721-3-2 class 2K4/2B1/2M1; lowest atmospheric pressure: 60 kPa
2. The MVVFD can be transported using cars, trains, or ships.
3. Operate with caution, and avoid rains, sun exposure, vibration, or clashing during transportation, and do not lay the equipment upside down.
4. When choosing transportation tools or paths, consider whether there is any limit such as height.
5. The bearing capacity of the transportation should must be greater than the actual weight of the HE1000 MVVFD.

Hoist requirements

- ▲ The equipment must be protected from collision and severe vibration during hoisting.
- ▲ The equipment must not be positioned upside down, and the tilt angle must not exceed 30°.
- ▲ The rope must be strong and long enough to hoist the equipment. The distance between the hook and equipment top must be at least 1.5 m, and the angle between the rope and equipment must be at least 60°.
- ▲ Two 2 m 16# steel channels must be applied at the equipment bottom, and two 1 m 10 cm x 10 cm planks must be secured to the equipment top. Gaps should be made in the steel channels to prevent the rope from sliding.

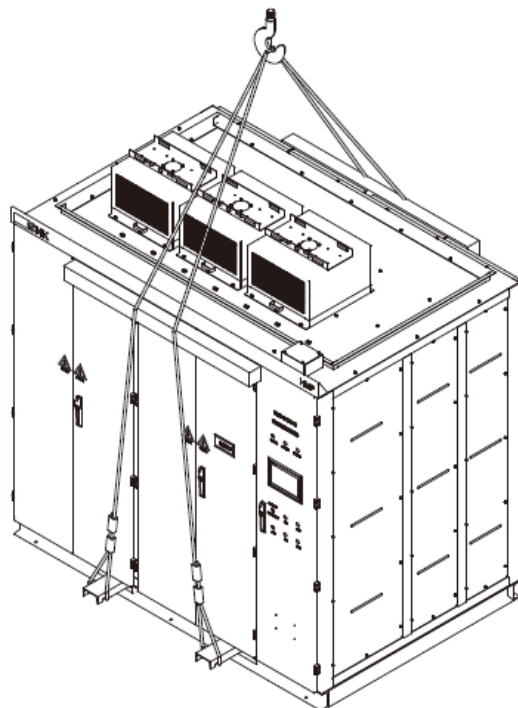

Model selection notice

The following specifications are required for choosing an HE1000 MVVFD. If you want to buy a product, fill in the detailed information in the following form and contact with us.

Customer name/Project name	
Process/Load name	
Load type	<input type="checkbox"/> Pump/Fan <input type="checkbox"/> Compressor <input type="checkbox"/> Extruder <input type="checkbox"/> Rotary kiln <input type="checkbox"/> Elevator <input type="checkbox"/> Winder <input type="checkbox"/> Multi-motor mechanically coupling <input type="checkbox"/> Others
Load features	<input type="checkbox"/> Large startup torque <input type="checkbox"/> Frequent startup and shutdown <input type="checkbox"/> Impulse load <input type="checkbox"/> Electrical brake required <input type="checkbox"/> Mechanical brake required <input type="checkbox"/> Others
Motor type and condition	<input type="checkbox"/> Squirrel-cage motor <input type="checkbox"/> wound-rotor motor <input type="checkbox"/> Synchronous motor <input type="checkbox"/> Newly installed motor <input type="checkbox"/> Existing motor
Motor specifications	Model: _____ Manufacturer: _____ Protection level (IP): _____ Rated output power: _____ kW Rated voltage: _____ kV Rated current: _____ A Rated frequency: _____ Hz Pole: _____ P Rated rotational speed: _____ rpm
Acceleration / Deceleration requirements	Acceleration period: _____ s Deceleration period: _____ s <input type="checkbox"/> No special requirement
Power supply	Voltage of the primary power: _____ V _____ Hz Rated capacity: _____ kVA Short-circuit current: _____ kA Control power voltage: _____ V _____ Hz
Control/Communication requirements	<input type="checkbox"/> External DCS/PLC hardwiring <input type="checkbox"/> Bus—protocol type <input type="checkbox"/> Control board <input type="checkbox"/> Onsite operation box <input type="checkbox"/> No special requirement <input type="checkbox"/> Others
Speed control/Feedback signal source	<input type="checkbox"/> Sensors <input type="checkbox"/> Upper-level DCS/PLC <input type="checkbox"/> Manual set <input type="checkbox"/> Others
Power frequency/Frequency switchover	Requiring power frequency/Frequency switchover <input type="checkbox"/> Yes <input type="checkbox"/> No Junction cabinet model: <input type="checkbox"/> Manual one-drive-one <input type="checkbox"/> Manual one-drive-two <input type="checkbox"/> Automatic one-drive-one <input type="checkbox"/> Automatic one-drive-two
Basis for adjusting operating status	<input type="checkbox"/> Signals collected by sensors <input type="checkbox"/> Onsite DCS system <input type="checkbox"/> Manual adjustment <input type="checkbox"/> Others
Installation position and environmental conditions	<input type="checkbox"/> Outdoor <input type="checkbox"/> Indoor <input type="checkbox"/> Newly constructed power distribution room <input type="checkbox"/> Existing power distribution room <input type="checkbox"/> Environment features: <input type="checkbox"/> Motor cable length: _____ m Cabling mode: <input type="checkbox"/> Cable tray or cable trench <input type="checkbox"/> Treading mode: <input type="checkbox"/> Top in and top out <input type="checkbox"/> Bottom in and bottom out <input type="checkbox"/> Others

Typical Customers

Coal company	Yangquan Coal Industry (Group) Company Limited, Shenhua Group, Xishan Coal Electricity Group Co., Ltd., China National Coal Group Corp, Shanxi Coal Transportation and Sales Group Co., Ltd.
Non-ferrous metal company	Aluminum corporation of China, Jin Jiang International (Group) Company Limited, Xinfa Group, Shandong Weiqiao Pioneering Group Co., Ltd., GALuminium Group, Qixing Aluminum Oxide
Iron & steel company	Guangxi Liuzhou Iron and Steel (Group) Company, Kunming Iron & Steel Holding Co., Ltd., Hunan Valin Steel Co., Ltd., Lengshuijiang Iron & Steel Co., Ltd., China RailwayEngineering Equipment Group Co., Ltd., Shougang Group, Anshan Iron and Steel Group Corporation, Liupanshui Iron & Steel Co., Ltd., Chongqing Iron & Steel (Group) Co., Ltd., Jiuquan Iron & Steel Group
Petroleum company	China National Petroleum Corporation, Sinopec Corp., China National Offshore Oil Corporation, Xinjiang Guanghui Petroleum Co., Ltd., Yangzhou Hengji Daxin International Chemical Industry Storage Limited Company, Hebei Xinhui Petroleum Technology Development Co., Ltd.
Chemical industry	Yangmei Chemical Co., Ltd., China Shenhua Coal to Liquid and Chemical Co., Ltd., Shanxi Lanhua Scin-tech Venture Co., Ltd., Ningbo Haiyue New Material Co., Ltd.
Power company	China Guodian Corporation, China Huadian Corporation, China Huaneng Group, China Power Investment Corporation, Shenyang Huanggu Thermal Power Co., Ltd., Shaoneng Thermal Power, Jianeng Thermal Power, Erdos Electric Power Co., Ltd.
Environmental Protection Company	Everbright Environmental Protection (China) Co., Ltd., Shenzhen Energy Environmental Engineering Co. Ltd., Yangzhou Taida Environmental Protection Co., Ltd.
Pharmaceutical company	Huizhou Sheng Rong Biotechnology Co., Ltd.
Food production	Guangxi Guitang Group Co., Ltd.
Mechanical company	Zhengzhou Textile Machinery Manufacturing Co., Ltd., Shenzhen Mepod Environmental Protection Equip. Co., Ltd., Tech-Long Packaging Machinery Co., Ltd., NFC (Shenyang) Metallurgical Machinery Co., Ltd.
Municipal project	Ningxia Greatwall water Supply Company, Guangzhou Water Supply Company, Shenzhen Water Group



Typical Cases

Power industry	<p>2 x 350 MW inducer fan MVVFD energy-saving project of a power plant in Dalian</p> <ul style="list-style-type: none"> ■ Load: inducer fan ■ Power: 3300 kW/6 kV ■ Quantity: 4 <p>.....</p> <p>MVVFD project of a power plant in Ordos, Inner Mongolia</p> <ul style="list-style-type: none"> ■ Load: primary fan, condensate pump ■ Power: 1400 kW/6 kV, 1800 kW/6 kV ■ Quantity: 12
Steel & iron industry	<p>Motor MVVFD energy-saving project of a sintering plant of a large-scale iron and steel company in Cangzhou, Hebei</p> <ul style="list-style-type: none"> ■ Load: primary exhaust fan, dust blower, dust blower at the equipment tail ■ Power: 5000 kW/10 kV, 1250 kW/10 kV, 1600 kW/10 kV ■ Quantity: 4 <p>.....</p> <p>Synchronous motor MVVFD energy-saving project of a sintering plant of a large-scale iron and steel company in Kunming</p> <ul style="list-style-type: none"> ■ Load: primary exhaust fan ■ Power: 6800 kW/6 kV ■ Quantity: 2
Non-ferrous metal industry	<p>Raw material grinder pulp pump MVVFD project of a large-scale state-owned aluminium company in Liangxing country, Shanxi</p> <ul style="list-style-type: none"> ■ Load: pulp pump ■ Power: 355 kW/10 kV ■ Quantity: 6 <p>.....</p> <p>MVVFD project of a large-scale aluminium company in Qingzhen, Guizhou</p> <ul style="list-style-type: none"> ■ Load: pulp pump, recirculation pump ■ Power: 400 kW/10 kV, 1120kW/10 kV ■ Quantity: 4
Cement industry	<p>5000T/D cement clinker production line MVVFD energy-saving project of a large-scale state-owned building materials company in Jiaguguan</p> <ul style="list-style-type: none"> ■ Load: High-temperature fan, dust blower ■ Power: 5600 kW/10 kV, 450kW/10 kV ■ Quantity: 2 <p>.....</p> <p>MVVFD project of a cement plant in Huaning county, Yunnan</p> <ul style="list-style-type: none"> ■ Load: High-temperature fan, recirculation fan ■ Power: 1250 kW/10 kV, 800 kW/10 kV ■ Quantity: 2
Other industries	<p>MVVFD for Artificial island construction use water injection pump of a large-scale state-owned petroleum and natural gas company in Tanghai county, Tangshan</p> <ul style="list-style-type: none"> ■ Load: water injection pump ■ Power: 630 kW/10 kV ■ Quantity: 1 <p>.....</p> <p>MVVFD control system for the 5-kilometer long pipe conveyor of a large-scale state-owned coal company in Shangshe county, Shanxi</p> <ul style="list-style-type: none"> ■ Load: multi-drive long pipe conveyor (two at the head and two at the tail) ■ Power: 670 kW/10 kV ■ Quantity: 6

Technical support

Micno has a professional pre-sales and after-sales technical support department. We send our technical support experts to customer sites for investigation and communications, and provide an optimum and customized overall solution for our customers based on their practical requirements.

With their accumulations in many projects, the technicians in our project engineering department are highly professional and experienced in project implementation and management. They are in charge of the onsite installation, commissioning, and operation of the MVVFDs, and guarantee your project quality.



Quality guarantee

Micno has achieved the ISO9001 certification, and a complete set of quality assurance system and procedure has been established in accordance with the ISO9001 system, realizing the quality control from design, procurement, and production to engineering service.

Micno has complete and standardized production and assembly workshops which include independent areas for production and assembly, commissioning, inspection, and logistics. We have first-class delivery commissioning and simulation laboratories and advanced inspection and test equipment. All of our products are tested and commissioned before delivery.

After-sales service

The after-sales service center is the service department responsible for products that are under or beyond the warranty term. After-sales service engineers can take up their jobs only after they have taken the employment skills training and a certificate has been granted. With the full coverage of after-sales centers in the regions where our Chinese offices are located, and professional toolkits, spare part boxes, and vehicles are ready for our after-sales service engineers, we can provide you with convenient and swift emergency treatment and maintenance services. After-sales response time: proving an initial solution in two hours upon a request received, and arriving on site in 24 hours 24-hour after-sales hotline: 400-861-8111

Customer training

While we strive to meet the requirements of our customers and provide them with quick and effective services, we also design a set of systematic technical training courses for them. Through the training, customers will be able to master the features of the equipment, and learn how to use, maintain, and repair the equipment and diagnose the fault, thereby prolong the lifespan of the equipment, lower the failure rate, and master the method for diagnosing and handling simple faults.

We have advanced and complete engineering laboratories that can simulate fault, and perform specific simulation test and online programming and commissioning, which can enable the hand-on practice of customers and make the training courses more targeted and efficient.

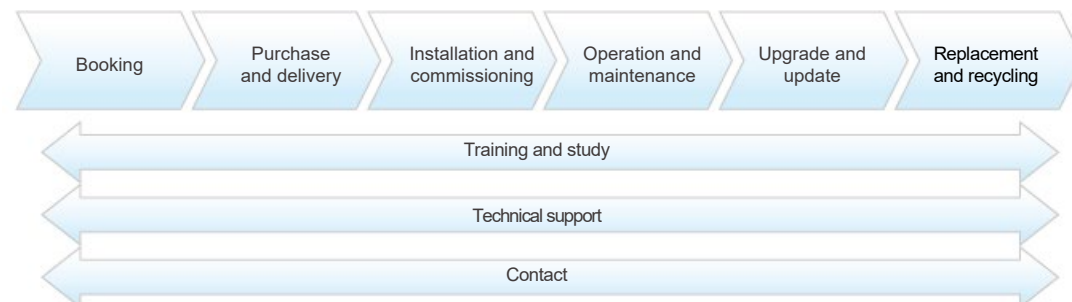

When it comes to the maintenance of high-quality end products, it has been the common objective of all the industries to earn the maximum yield with the minimum cost. One of Micno's key roles is, on the basis of expectable, secure, and low-cost operating mode, to help the customers obtain the maximum operating time by optimizing the lifespan of our products.

When we were asked by a customer for the first time about how to handle and recycle the used MVVFD, we set forth a solution and started to provide services covering the entire value chain. Such services include training, and technical support and communications, and can be obtained in any of the sales and service networks across the world.

Maximizing return on investment

The MVVFD lifespan management model is the core of Micno services. All the effective services of Micno products are included in this model, which directly illustrates effective and ineffective services and phases.

The detailed product maintenance time table is also based on this four-phase model. In this way, customers can obtain the timeliness of services such as replacement for effective components. Customers can also decide when to replace and upgrade the product.

With such professional lifespan management of Micno MVVFDs, the return on investment is maximized.

Micno MVVFD lifespan management model

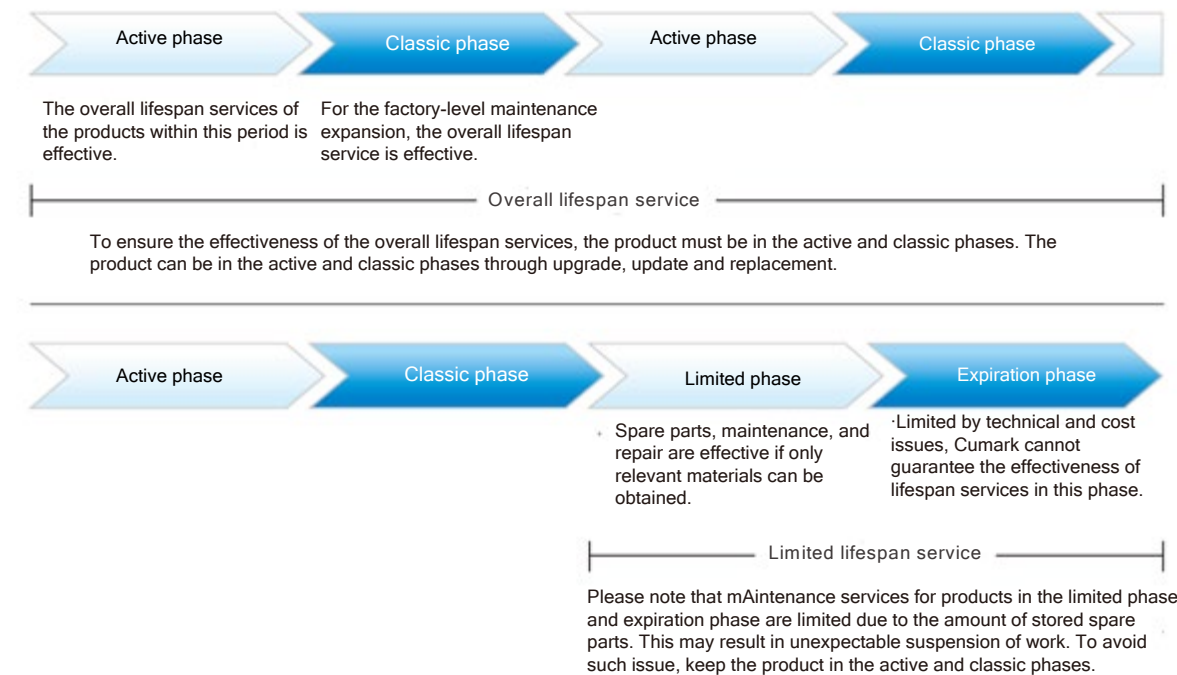

Micno enhances the customer support and improves efficiency by following the model for managing the lifespan of the product.

Lifespan services include: model selection and size measurement, installation and commissioning, prevention, improvement-based maintenance, remote services, spare part services, training and study, technical support, upgrade, refurbishment, replacement, and recycling.